

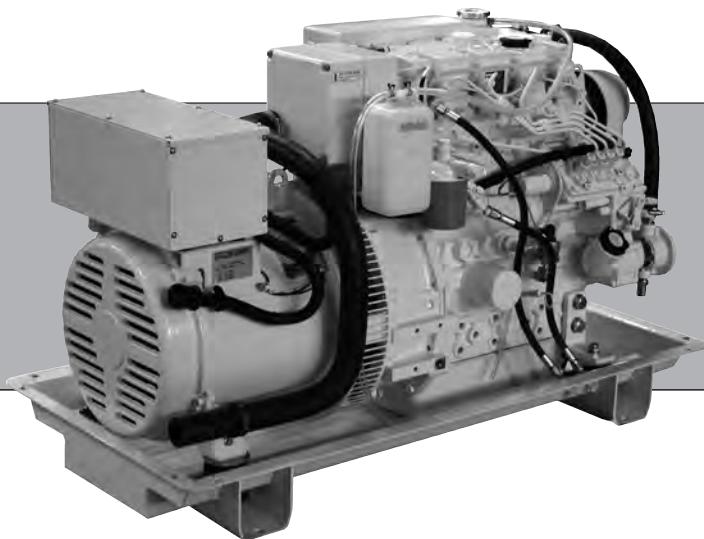

# OPERATOR'S MANUAL

## OM844W3

For Models: M844W3, M844DW3,  
M844LW3, M844LW3G, M20CRW3



[www.northern-lights.com](http://www.northern-lights.com)



— CALIFORNIA —  
Proposition 65 Warning:

**Breathing Diesel engine exhaust and some of its constituents are known to the State of California to cause cancer, birth defects, and other reproductive harm.**

- \* Always start and operate the engine in a well-ventilated area.
- \* If in an enclosed area, vent the exhaust to the outside.
- \* Do not modify or tamper with the exhaust system.
- \* Do not idle the engine except as necessary.

**For more information, go to [www.P65warnings.ca.gov/diesel](http://www.P65warnings.ca.gov/diesel).**

**Northern Lights**

4420 14th Avenue NW  
Seattle, WA 98107  
Tel: (206) 789-3880  
Fax: (206) 782-5455

Copyright ©2018 Northern Lights, Inc.  
All rights reserved. Northern Lights™, and  
the Northern Lights logo are trademarks of  
Northern Lights, Inc.

Printed in U.S.A.  
PART NO.: OM844W3 5/19



# OPERATOR'S MANUAL

for Models

M844W3, M844DW3, M844LW3, M844LW3G and M20CRW3

*Read this operator's manual thoroughly before starting to operate your equipment.*

*This manual contains information you will need to run and service your new unit.*

## Table of Contents

<b>INTRODUCTION</b> .....	<b>2</b>	<b>SERVICING</b>	
Unit Identification .....	<b>2</b>	Lubrication - General .....	<b>16</b>
Model Numbers .....	<b>2</b>	Checking Oil .....	<b>16</b>
Serial Numbers .....	<b>2</b>	Oil Changes .....	<b>16</b>
<b>WARRANTY</b> .....	<b>3</b>	Changing Oil Filter .....	<b>16</b>
<b>SAFETY RULES</b> .....	<b>3-7</b>	Air Cleaner .....	<b>17</b>
<b>LOCK OUT / TAG OUT PROCEDURES</b> .....	<b>8</b>	V-Belts .....	<b>17</b>
<b>COMPONENT LOCATIONS</b>		Valve Clearances .....	<b>17</b>
M844W3 Marine Generator		Fuels - General .....	<b>18</b>
(Gem Series base frame) .....	<b>9</b>	Fuel Filters .....	<b>18</b>
M844W3 Marine Generator		Bleeding the Fuel System .....	<b>19</b>
(2011 base frame) .....	<b>10</b>	Injector Service .....	<b>20-21</b>
M20CRW3 Commercial Generator .....	<b>11</b>	Injection Pump .....	<b>20</b>
<b>CONTROL PANELS</b> .....	<b>12</b>	Cooling System - General .....	<b>22</b>
<b>OPERATING PROCEDURES</b>		Water Quality .....	<b>22</b>
Break-in Period .....	<b>13</b>	Checking Coolant Level .....	<b>22</b>
Before Starting .....	<b>13</b>	Cooling System Flushing .....	<b>22</b>
Starting .....	<b>13</b>	Heat Exchanger .....	<b>22</b>
Operating .....	<b>13</b>	Raw Water Pump .....	<b>23</b>
Stopping .....	<b>13</b>	Generator Ends .....	<b>23</b>
Shutdowns and Alarms .....	<b>14</b>	Electrical System - General .....	<b>23</b>
Spare Parts .....	<b>14</b>	Glow Plugs .....	<b>23</b>
<b>SERVICING SCHEDULE CHART</b> .....	<b>15</b>	Booster Batteries .....	<b>24</b>
		Battery Care .....	<b>24</b>
		PTO Care .....	<b>24</b>
		Winterizing / Out-of-Service .....	<b>24</b>
		<b>TROUBLESHOOTING</b>	
		Electrical .....	<b>25</b>
		Engine .....	<b>26 - 28</b>
		<b>WIRING DIAGRAMS</b>	
		AC Electrical .....	<b>29 - 30</b>
		DC Electrical .....	<b>31 - 38</b>
		Panel Diagrams .....	<b>31 - 47</b>

### Proprietary Information

This publication is the property of Northern Lights, Inc.

It may not be reproduced in whole or in part without the written permission of Northern Lights, Inc.

© Northern Lights, Inc. All rights reserved. Litho U.S.A. Publication number OM844W3 5/19

## Introduction

Servicing of marine engines and generator sets presents unique problems. In many cases boats cannot be moved to a repair facility. Marine engines cannot be compared to the servicing of automobiles, trucks or even farm equipment. Failures often occur in remote areas far from competent assistance. Marine engines are taxed far more severely than auto or truck engines; therefore, maintenance schedules must be adhered to more strictly.

Failures can begin with minor problems that are overlooked and become amplified when not corrected during routine maintenance.

As operator, it is your obligation to learn about your equipment and its proper maintenance. This is not a comprehensive technical service manual. Nor will it make the reader into an expert mechanic. Its aim is to aid you in maintaining your unit properly.

## Unit Identification

### MODELS INCLUDED

This manual covers the operating instructions for:

**M844W3** marine generator sets,  
**M844DW3** marine generator sets,

**M844LW3** marine generator sets,  
**M844LW3G** marine generator sets, and  
**M20CRW3** commercial generator sets.

## Model Numbers

Model numbers give the unit's application, block model, aspiration, and RPM:

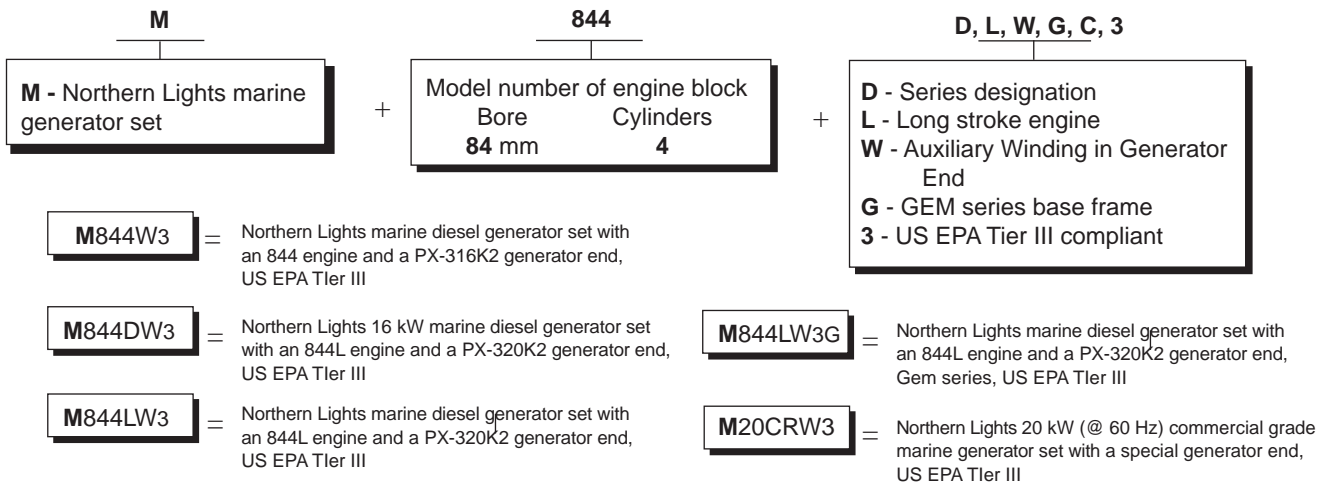

## Serial Numbers



*Generator set serial number plate.*

Your set has three serial numbers: ① an engine number stamped on the block, ② a generator plate, and ③ a generator set plate.

Use the serial number on the generator set plate when ordering parts or in correspondence. The generator set plate is found on the service side of the generator and resembles the drawing at left.

## Warranty

A warranty registration certificate is supplied with your set. It entitles the original purchaser of our equipment to a warranty covering material or assembly faults. The extent of coverage is described in the Limited Warranty Statement. We recommend that you study the statement carefully.

**NOTE:** If the warranty is to apply, the servicing instructions outlined in this manual must be followed. If further information is needed, please contact an authorized dealer or the factory.

## Safety Rules

**DANGER:** Northern Lights generator sets and /or any other diesel powered equipment provided by NLI is not provided with spark arresting or explosion proof components, and therefore is not to be installed in the presence of combustible gases having a flash point of 43.3 Degrees C (110 Degrees F) or lower, such as Gasoline, Propane, Natural Gas or other similar fuel sources.



**NOTICE:** Accident reports show that careless use of engines causes a high percentage of accidents. You can avoid accidents by observing these safety rules. Study these rules carefully and enforce them on the job.

### IMPORTANT SAFETY INSTRUCTIONS.

Electromagnetic equipment, including generator sets and their accessories, can cause bodily harm and life threatening injuries when improperly installed, operated or maintained. To prevent accidents be aware of potential dangers and act safely.



**READ AND FOLLOW ALL SAFETY INSTRUCTIONS IN THIS MANUAL, PRIOR TO THE INSTALLATION OF ANY GENERATOR SET OR ACCESSORY. KEEP THESE INSTRUCTIONS FOR FUTURE REFERENCE.**

### Recognize Safety Symbols and Instructions

In addition to the information found in this section, this operator's manual uses three different signal words to outline potential dangers of a specific nature.

<b>DANGER</b>	DANGER indicates a hazardous situation which, if not avoided, will result in death or serious injury.
<b>WARNING</b>	WARNING indicates a hazardous situation which, if not avoided, could result in death or serious injury.
<b>CAUTION</b>	CAUTION indicates a hazardous situation which, if not avoided, could result in minor or moderate injury.

### Follow All Safety Instructions

Carefully read and understand all safety messages in this manual and on your machine's safety signs. Keep signs in good and clean condition. Replace missing or damaged signs. Be sure new equipment components and

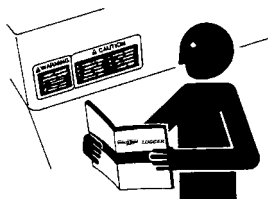

repair parts include the current safety signs. For replacement signs, proper placement of safety signs or clarification on any safety issue, consult your Northern Lights dealer or the factory.

There can be additional safety information contained on parts and components from outside suppliers that is not reproduced in this manual. Consult the suppliers for additional safety information.

Learn how to operate the machine and how to use the controls properly. Only trained personnel should operate machines, or work on or around them.

Keep you machine in proper working condition. **UNAUTHORIZED MODIFICATIONS TO THE MACHINERY MAY IMPAIR ITS FUNCTION AND SAFETY PARAMETERS.**

### Prevent Bypass and Accidental Starting



Do not start engine by shorting across start terminal. Engine will start if normal circuitry is bypassed, creating a hazard by runaway machinery.

Start engine only from operator's station.

## Safety Rules (Continued)

### Handle Fuel Safely - Avoid Flames

#### **! WARNING**

Diesel is highly flammable and should be treated with care at all times. Do not refuel while smoking or when near sparks or open flame.

**ALWAYS STOP ENGINE BEFORE FUELING MACHINE.** Always fill portable fuel tank outdoors. Never fuel a hot engine. Prevent accidental discharge of starting fluids by storing all cans in a cool, safe place, away from sparks or open flame. Store with cap securely on container. Never incinerate or puncture a fuel container.



Prevent fires by keeping machine clean of accumulated trash, grease and debris. Always clean any spilled fuel as swiftly as possible. Do not store oily rags, which can ignite and burn spontaneously.

Be prepared if a fire starts. Keep a first aid kit and fire extinguisher handy. Keep emergency contact numbers for fire department, doctors, ambulance and hospital near the telephone.

### Service Machines Safely

#### **! DANGER**

Do not wear a necktie, scarf, necklace, rings or other jewelry, or any loose clothing when working near moving parts. Tie long hair behind your head. If any of these items get caught in moving machinery, severe injury or death could result.

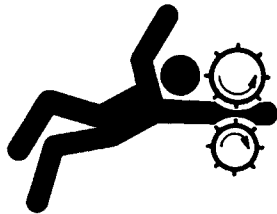

Check for any loose electrical connections or faulty wiring.

Look completely around engine to make sure that everything is clear before starting.

### Wear Protective Clothing

#### **! WARNING**

To prevent catching anything in moving machinery, always wear close fitting clothes and safety equipment appropriate to the job.

Prolonged exposure to loud noise can cause hearing loss or impairment. Wear suitable authorized hearing protection, such as earmuffs or plugs to protect against loud noises.

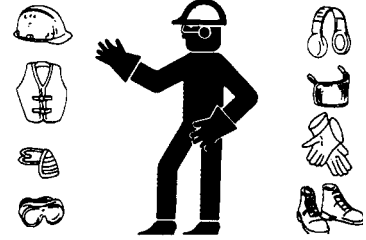

Operating equipment requires the full attention of the operator. Do not use radio or music headphones while operating machinery.

### Practice Safe Maintenance

#### **! CAUTION**

Understand all service procedures before starting work. Keep area clean and dry. Never lubricate, service, or adjust machine while it is in operation.



Keep hands, feet and clothing away from power-driven equipment. When shutting down an engine, disengage all power and operator controls. Allow the engine to cool completely before beginning any service work.

*Securely support any machinery elements that must be raised for service work with support or lifting machinery specifically intended for that purpose.*

Keep all parts in good conditions and properly installed. Fix damage immediately. Replace any worn or broken parts. Remove any build up of grease, oil or debris.

Disconnect battery ground cable (-) before making any adjustments or service work.

## Safety Rules (Continued)

### Stay Clear of Rotating Drivelines

#### DANGER

Entanglement in rotating drivelines can cause serious injury or death. Keep shields in place at all times. Make sure that rotating shields turn freely in pace with the drivelines.



Do not wear loose fitting equipment around rotating drivelines. Stop the engine and make sure that all moving parts have stopped before making any adjustments, connections, or performing any other type of service to the engine or other driven equipment.

### Install all Safety Guards

#### WARNING

Direct contact with rotating fans, belts, pulley and drives can cause serious injury.

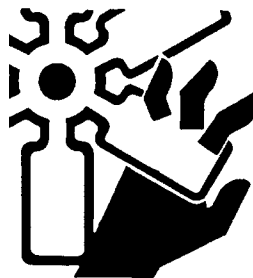

Keep all guards in place at all times during engine operation.

Wear close-fitting clothes. Stop the engine and be sure all fans, belts, pulleys and drives are stopped before making adjustments, connections, or cleaning near fans and their components.

Do not allow anything on your person to dangle into or come in contact with a moving fan, belt, pulley or drive. Fans can act as vacuums and pull materials up from below, so avoid that area as well while in service.

### Safe Battery Handling

#### WARNING

#### Prevent Battery Explosions

Battery gas is highly flammable. Battery explosions can cause severe injury or death. To help prevent battery explosions, keep sparks, lighted matches and open flame away from the top of battery. When checking battery electrolyte level, use a flashlight.

Never check battery charge by contacting the posts with a metal object. Use a voltmeter or hydrometer.



Frozen batteries may explode if charged. Never charge a battery that has not been allowed to warm to at least 16°C (60°F).

Always remove grounded (-) battery clamp first and replace ground clamp last.

Sulfuric acid in battery electrolyte is poisonous and strong enough to burn skin, eat holes into clothing and other materials, and cause blindness if splashed into eyes.

#### To Avoid Hazards:

- Fill batteries only in well-ventilated areas.
- Wear appropriate eye protection and rubber gloves.
- Never use air pressure to clean batteries.
- Wear appropriate ventilation equipment to avoid inhaling fumes when adding electrolyte.
- Do not spill or drip electrolyte.
- Use correct jump-start procedure if required.

#### If acid is spilled on skin or in eyes:

1. Flush skin with water.
2. Apply baking soda or lime to help neutralize acid.
3. Flush eyes with water for 15-30 minutes.
4. Get medical attention immediately.

#### If acid is swallowed:

1. DO NOT induce vomiting.
2. Drink large amounts of water or milk, without exceeding 2 liters (2 quarts)
3. Get medical attention immediately

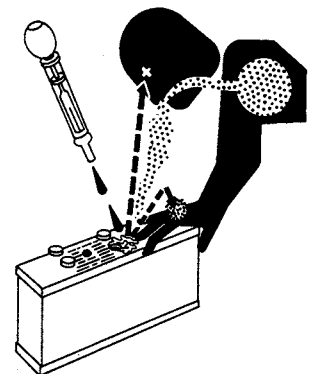

#### WARNING

Battery posts, terminals, and related accessories can contain lead and lead compounds, chemicals known to the State of California to cause cancer and reproductive harm. Wash hands after handling.



## Safety Rules (Continued)

### Handle Chemical Products Safely

#### **! WARNING**

Direct exposure to hazardous chemicals can cause serious injury. Among the potentially hazardous chemicals that may be used with Northern Lights products are lubricants, coolants, paints and adhesives.

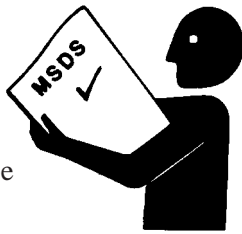

All potentially hazardous chemicals come with a Material Data Safety Sheet (MSDS). The MSDS provides specific details on chemical products, including physical hazards, safety procedures and emergency response techniques

Read and understand the MSDS for each chemical before you start any job that includes it. Follow the procedures and use appropriate equipment exactly as recommended.

Contact your Northern Lights dealer or Northern Lights factory for MSDS's used on Northern Lights products.

### Work in Well Ventilated Areas

#### **! CAUTION**

Exhaust fumes from engines contain carbon monoxide and can cause sickness or death. Work in well ventilated areas to avoid prolonged exposure to engine fumes. If it is necessary to run an engine in an enclosed area, route the exhaust fumes out of the area with an approved, leak proof exhaust pipe extension.

### Remove Paint Before Welding or Heating

#### **! WARNING**

Hazardous fumes can be generated when paint is heated by welding, soldering or using a torch. To avoid potentially toxic fumes and dust, remove paint before heating.

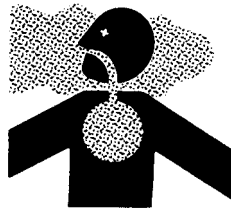

- Remove paint a minimum of 100 mm (4 in.) from the area that will be affected by heat.
- If paint cannot be removed, wear an approved respirator.
- If you sand or grind paint, use an approved respirator.
- If you use solvent or paint stripper, remove stripper with soap and water before welding. Remove solvent or paint stripper containers from the area.
- Allow at least 15 minutes for fumes to disperse before welding or heating.

Do not use a chlorinated solvent in an area where welding will occur. Work only in areas that are well ventilated. Dispose of paint and solvent properly.

### Service Cooling System Safely

#### **! WARNING**

Opening a pressurized cooling system can release explosive fluids and causing serious burns. Before opening any pressurized cooling system, make sure the engine has been shut off. Do not remove a filler cap unless it is cool enough to comfortably grip with bare hands. Slowly loosen cap to relieve pressure before opening fully.



### Avoid High Pressure Fluids

#### **! WARNING**

Relieve pressure prior to disconnecting pressurized lines. Escaping fluid under pressure can penetrate the skin causing serious injury. Always relieve pressure before disconnecting hydraulic or other pressurized lines. Tighten all connections firmly before re-applying pressure.



If searching for leaks, use a piece of cardboard. Always protect your hands and other body parts from high-pressure fluids.

If an accident occurs, see a doctor immediately. Any high pressure spray injected into the skin must be removed within a few hours to prevent the risk of gangrene or other infection.

### Avoid Heating Near Pressurized Fluid Lines

#### **! WARNING**

Flammable spray can be generated by heating near pressurized fluid lines, resulting in severe burns and bodily injury. Pressurized lines can rupture when heat goes beyond the immediate flame area. Do not weld, solder or use a torch or open flame near pressurized lines or other flammable fluids.





## Safety Rules (Continued)

### Do Not Open High-Pressure Fuel System

#### **DANGER**



Many Northern Lights engines use high-pressure fuel injection. High-pressure fluid remaining in fuel lines can cause serious injury. Do not disconnect or attempt any repair of fuel lines, sensors, or other components between the high-pressure fuel pump and nozzles on engines with high pressure fuel systems.

**ONLY AUTHORIZED TECHNICIANS CAN PERFORM REPAIRS ON AN HIGH PRESSURE FUEL INJECTION SYSTEMS.**

### Avoid Hot Exhaust

#### **WARNING**



Avoid exposure to and physical contact with hot exhaust gases. Exhaust parts and streams can reach high temperatures during operation, leading to burns or other serious injury.

Cleaning exhaust filters can also lead to exposure to hot exhaust gas and the injury risk associated with it. Avoid exposure to and physical contact with hot exhaust gases when cleaning exhaust filters.

During auto or manual/stationary exhaust filter cleaning operations, the engine will run at elevated temperatures for an extended period of time. Exhaust parts and streams can reach high temperatures during operation, leading to burns or other serious injury.

### Avoid Harmful Asbestos Dust

#### **WARNING**

Inhaling asbestos fibers may cause lung cancer. Avoid breathing any dust that may be generated when handling components containing asbestos fibers, including some gaskets.



The asbestos used in these components is usually found in a resin or otherwise sealed. Normal handling of these components is not dangerous, as long as airborne dust containing asbestos is not generated.

Avoid creating dust. Never use compressed air for cleaning. Avoid brushing or grinding materials containing asbestos. When servicing, wear an approved respirator. A special vacuum cleaner is recommended to clean asbestos. If this vacuum is not available, apply a mist of oil or water on the material containing asbestos. Keep all bystanders away from any area where asbestos dust may be generated.

### Use Proper Lifting Equipment and Techniques

#### **WARNING**



Lifting heavy components incorrectly can cause severe injury or damage to machinery. Avoid unbalanced loads. Do not use lifting eyes. Lift the generator set using lifting bars inserted through the lifting holes on the skid. Follow all recommended removal and installation procedures in this and associated Northern Lights manuals.

### Use Proper Tools

#### **CAUTION**



Makeshift tools and procedures can create safety hazards. Always use appropriate tools for the job.

Use power tools only to loosen threaded parts and fasteners. For loosening and tightening hardware, always use the correct sized tools.

Do not use US measurement tools on metric fasteners, or vice versa. Use only service parts that meet Northern Lights specifications.

### Dispose of Waste Properly

#### **CAUTION**

Disposing of waste improperly can threaten the environment and lead to unsafe working conditions. Potentially harmful waste used in Northern Lights equipment can include oil, fuel, coolant, filters and batteries.

Use leakproof containers to drain fluid. Do not use food or beverage containers that may mislead someone into drinking from them.

Do not pour waste onto the ground, down a drain or into any water source.

## Lock Out / Tag Out Procedures

### Scope

During maintenance, repairs or retooling of a Northern Lights generator set, simply turning the machine off or unplugging it while it is being worked on does not give enough protection to others who are not performing the maintenance or repair. Many serious accidents happen when someone thought the machine was turned off, or all of its energy was safely blocked or released.

### General Policy

#### CAUTION

To avoid dangerous or hazardous situations, refrain from any of the following:

- Removing or bypassing a guard or other safety device
- Placing any part of your body in a position where you could be caught by moving machinery.
- Cleaning or oiling machinery when in operation.
- Adjusting circuits, chillers, pumps, air handlers, valves, circuit breakers or fans while in operation.
- Working on piping or high pressure systems.

### Lock Out/Tag Out Instructions - Electrical Equipment

#### WARNING

Be sure the equipment's ON/OFF switch is in the OFF position and is unplugged from any electrical source before attempting to perform any type of work on the equipment. Obtain an electrical plug cap cover with a lockset. Secure the plug terminal end using the electrical plug lockout cap. Lock the cap and retain the key.

If the equipment is directly wired into an electrical box with a shut off switch, obtain a lock pad and/or the appropriate colored tags and place the lock and tag through the shut off lever. Retain the key until the repair is completed and the machine is safe to start. Be certain the shut off lever is in the OFF position before restarting. NEVER give a lock out key to unauthorized personnel.

If the equipment is directly wired into an electrical box without a shut off switch and lock out capability, then a circuit breaker lock out will be required. Obtain a circuit lock and tag set. Install the lock onto the circuit breaker box. Ensure the unit ON/OFF switch is in the OFF position before restarting.

### Lock Out/Tag Out Instructions - Pneumatic and Hydraulic Equipment

#### WARNING

For servicing pneumatic and hydraulic equipment, the following additional procedures must be implemented, following completion of lock out/tag out procedures for the unit to be serviced:

Shut off air, water or supply valves at the equipment to be serviced.

Check the local bleed-off point for completed release of pressurized air, water or oil.

If shutting off of air, water or other material cannot be achieved at the local supply valve, shut off valves further back in the system and re-check the bleed-off point until complete shut-off is achieved.

Affix a DO NOT OPERATE tag to each valve handle that requires shut off. Each DO NOT OPERATE tag must be signed and dated by the authorized technician servicing the equipment.

### Lock Out/Tag Out Instructions - Air Hose Connected Pneumatic Equipment

#### WARNING

Equipment connected to the compressed air system through an air hose with a detachable fitting must be shutdown and unplugged. Excess air must be bled prior to removing the air hose, prior to any maintenance or repair activities.

Affix a DO NOT OPERATE tag to the air hose near the detachable fitting. Each DO NOT OPERATE tag must be signed and dated by the authorized technician servicing the equipment. Check that the equipment cannot be operated by activating the ON switch.

### Stored Energy

#### WARNING

Immediately after applying Lock Out or Tag Out devices, ensure that all potentially hazardous stored or residual energy is relieved, disconnected, restrained and otherwise rendered safe.

### Verification of Isolation

#### CAUTION

Verify the machinery or equipment is actually isolated and de-energized prior to beginning work on a machine or on equipment that has been locked out.

### Restarting Procedures

#### CAUTION

Follow the procedures below prior to restoring energy:

- Ensure that all machinery or equipment is properly reassembled. Inspect the machinery or equipment to verify non-essential items have been removed.
- Ensure that all personnel are safely outside danger zones. Notify personnel that lock out/tag out devices have been removed and energy will be reapplied.
- Only authorized personnel may remove lock out/tag out devices or notices.

---

## Marine Generator Component Locations

---

**Image not available at time of publication.  
Please consult factory for more information.**

**Figure 1C and 2C:** M844LW3G Gem series (s/n: 8442-56160 and above)

- |  |                            |  |                                 |
|--|----------------------------|--|---------------------------------|
| 1. DC Circuit Breaker<br>(not visible. Callout for approximate location) | 9. Injection Pump          | 19. Oil Filter   | 25. Coolant Drain               |
| 2. Coolant Recovery Tank   | 10. Oil Fill (Side)        | 20. Lube Oil Drain   | 26. Wet Exhaust Elbow           |
| 3. Secondary Fuel Filter   | 11. Raw Water Pump         | 21. Fuel Lift Pump   | 27. Junction Box                |
| 4. Fuel Return Line  | 12. Raw Water Inlet        | 22. Control Panel Plug-in<br>(not visible. Callout for approximate location) | 28. Starter                     |
| 5. Fuel Injector   | 13. Vibration Mount        | 23. AC Circuit Breaker for Automatic Voltage Regulator                       | 29. Alternator                  |
| 6. Oil Fill (Top)  | 14. Oil Pressure Sender    | 24. Expansion Tank/Exhaust Manifold/Heat Exch. Tank                          | 30. Belt Guard                  |
| 7. Coolant Fill  | 15. Freshwater Block Drain |  | 31. Coolant Thermostat (behind) |
| 8. Fresh Water Pump  | 16. Fuel Inlet Line        |  | 32. Water Temperature Sender    |
|  | 17. Fuel Return Line       |  |                                 |
|  | 18. Oil Dipstick           |  |                                 |

## Marine Generator Component Locations

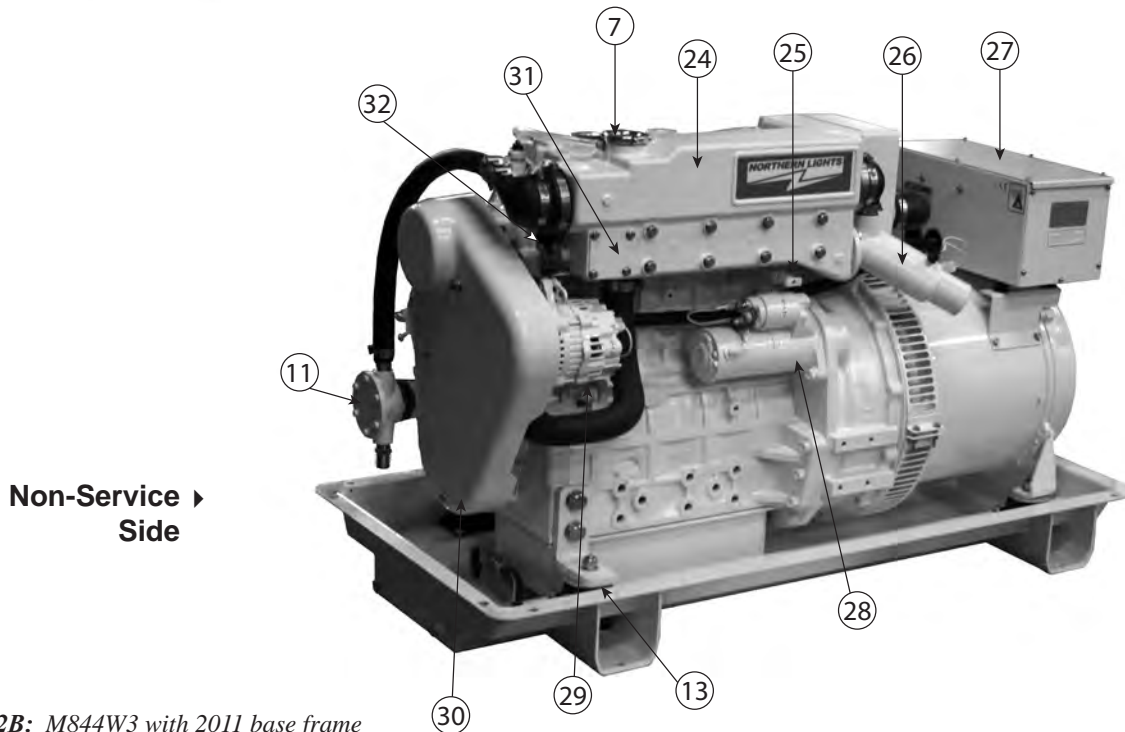
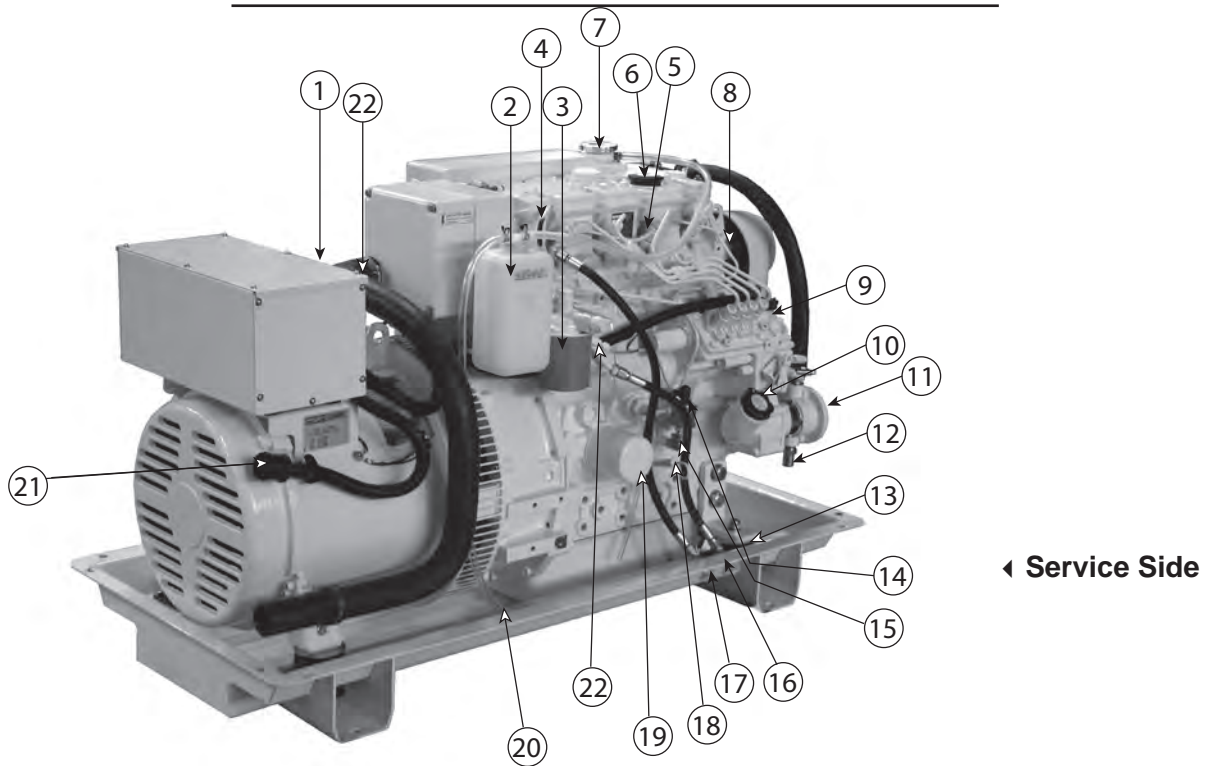

**Figure 1B and 2B:** M844W3 with 2011 base frame

- |  |                            |  |                                 |
|--|----------------------------|--|---------------------------------|
| 1. DC Circuit Breaker<br>(not visible. Callout for approximate location) | 9. Injection Pump          | 19. Oil Filter   | 25. Coolant Drain               |
| 2. Coolant Recovery Tank   | 10. Oil Fill (Side)        | 20. Lube Oil Drain   | 26. Wet Exhaust Elbow           |
| 3. Secondary Fuel Filter   | 11. Raw Water Pump         | 21. Fuel Lift Pump   | 27. Junction Box                |
| 4. Fuel Return Line  | 12. Raw Water Inlet        | 22. Control Panel Plug-in<br>(not visible. Callout for approximate location) | 28. Starter                     |
| 5. Fuel Injector   | 13. Vibration Mount        | 23. AC Circuit Breaker for Automatic Voltage Regulator                       | 29. Alternator                  |
| 6. Oil Fill (Top)  | 14. Oil Pressure Sender    | 24. Expansion Tank/Exhaust Manifold/Heat Exch. Tank                          | 30. Belt Guard                  |
| 7. Coolant Fill  | 15. Freshwater Block Drain |  | 31. Coolant Thermostat (behind) |
| 8. Fresh Water Pump  | 16. Fuel Inlet Line        |  | 32. Water Temperature Sender    |
|  | 17. Fuel Return Line       |  |                                 |
|  | 18. Oil Dipstick           |  |                                 |

## Marine Generator Component Locations

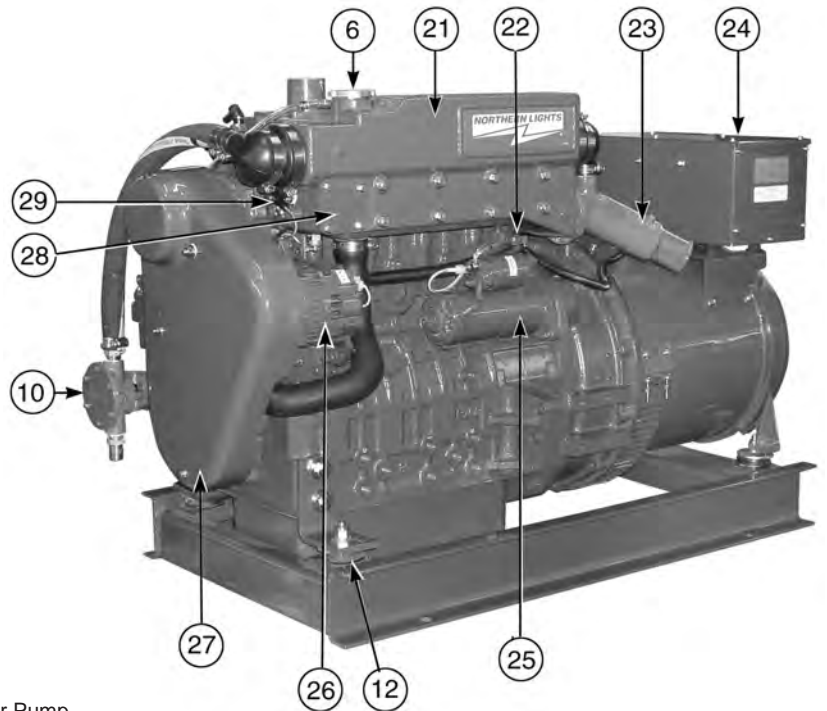
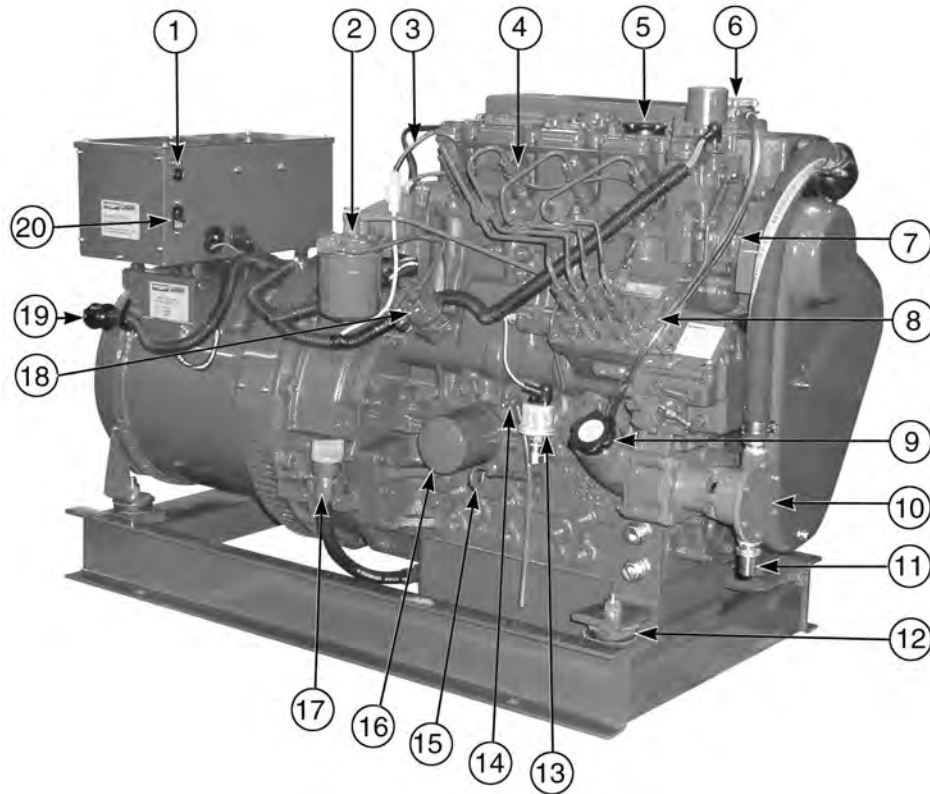

**Figure 2A and 2B: M20CRW3**

- |                          |                            |  |                                 |
|--------------------------|----------------------------|--|---------------------------------|
| 1. DC Circuit Breaker    | 10. Raw Water Pump         | 19. Control Panel Plug-in                              | 24. Junction Box                |
| 2. Secondary Fuel Filter | 11. Raw Water Inlet        | 20. AC Circuit Breaker for Automatic Voltage Regulator | 25. Starter                     |
| 3. Fuel Return Line      | 12. Vibration Mount        | 21. Expansion Tank/Exhaust Manifold/Heat Exch. Tank    | 26. Alternator                  |
| 4. Fuel Injector         | 13. Oil Pressure Sender    | 22. Coolant Drain                                      | 27. Belt Guard                  |
| 5. Oil Fill (Top)        | 14. Freshwater Block Drain | 23. Wet Exhaust Elbow                                  | 28. Coolant Thermostat (behind) |
| 6. Coolant Fill          | 15. Oil Dipstick           |  | 29. Water Temperature Sender    |
| 7. Fresh Water Pump      | 16. Oil Filter             |  |                                 |
| 8. Injection Pump        | 17. Oil Drain              |  |                                 |
| 9. Oil Fill (Side)       | 18. Fuel Lift Pump         |  |                                 |



## Control Panels

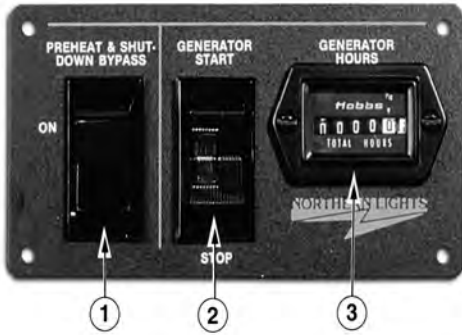

Figure 3-A: Series 1-B Generator Control Panel



Figure 3-B: Series 3 Generator Control Panel



Figure 3-C: Series 4 Generator Control Panel

### 1. SHUTDOWN BYPASS-PREHEAT SWITCH

Two functions are built into this switch: the preheating of the engine, and bypassing of the engine safety shutdown circuit. Hold switch in the ON position 10 - 20 seconds before starting the engine, and continue holding on during engine cranking. Release the switch as soon as the engine is running. Holding the switch on too long can burn out the heater element.

### 2. ENGINE CONTROL SWITCH

To start the engine, hold this switch in the START position until the engine is running.

*NOTE: Excessive cranking of marine sets equipped with water lift muffler systems can cause engine damage. See page 7.*

After the engine starts, release the switch and it will return to RUN position. To stop the engine, hold the switch in the STOP position until the engine has completely stopped.

*NOTE: The rocker switch is used on Series 1 panels only, and has a light that glows when the set is running.*

### 3. HOUR METER

Keeps track of engine running time.

### 4. OIL PRESSURE GAUGE

Shows the oil pressure in the engine lubricating system.

### 5. ENGINE TEMPERATURE GAUGE

Registers the temperature of the engine coolant.

### 6. D.C. VOLTMETER OR AMMETER

When the engine is stopped, the voltmeter indicates the condition of the battery. When the engine is running, the voltmeter indicates the voltage output of the alternator.

### For Series 4 Control Panels Only:

### 7. A.C. VOLTMETER

Shows the generator output voltage.

### 8. FREQUENCY METER (Hertz)

The frequency meter indicates alternating current frequency: 60 Hz (1800 RPM), or 50 Hz (1500 RPM).

### 9. AMMETER/VOLTMETER SELECTOR SWITCH

Used to check voltage and current of each phase.

### 10. A.C. AMMETER

Shows the generator load on each phase. The phase is selected with the Ammeter Selector switch (Item 9).



## Operating Procedures

### BREAK-IN PERIOD

1. The first 100 hours on a new or reconditioned engine are critical to its life and performance.
2. Operate the engine under various conditions, particularly heavy loads with minimal idling, to help seat engine components properly.
3. Frequently check the engine temperature and oil pressure gauges (sets with Series 3 or 4 panels).
4. Oil consumption is greater during break-in as piston rings take time to seat.
5. Break-In Oil Changes: Change engine oil and filter at 50 hours. Change oil and filter again at 100 hours (consult Lubricants section for oil recommendation), then at every 250 hours.

### BEFORE STARTING

1. Check the water level by removing the pressure cap from the expansion tank or radiator. In order to give the cooling water an opportunity to expand, the level should be about 1 in. (2.5 cm) below the filler cap sealing surface when the engine is cold.

**CAUTION:** Use protective clothing and open the filler cap carefully when the engine is warm to prevent burns.



2. Check the oil level in the crankcase with the dipstick. The oil level must be in the waffled area on the stick. Never allow the level to go below this area. Always add the same viscosity of oil as is already in the crankcase.
3. Check the fuel tank level and open any fuel valves.
4. Close the sea-cock; check, clean, and reassemble the sea strainer and re-open the sea-cock.
5. Place the battery switch in the ON position.
6. **NOTE:** The battery switch must always be kept ON while the engine is running. If the switch is turned OFF while the engine is running, the battery charging regulator could be ruined.

### STARTING

1. Hold the Shutdown Bypass-Preheat switch in the ON position for 10 to 20 seconds before starting a cold engine. Holding the switch too long can burn out the glow plugs. This step is not necessary if the engine is already warm.
2. While holding the Shutdown Bypass-Preheat switch in the ON position, push the Engine Control switch to the START position.
3. As soon as the engine starts, release the start switch and continue to hold the bypass/preheat switch for an additional five seconds. Do not crank the starter for more than 10 seconds consecutively. If the engine fails to start with the first attempt, be sure that it has stopped completely before re-engaging.

**NOTE:** Excessive cranking of the starter on Marine sets equipped with a water lift muffler can cause engine damage. If the engine does not start after three 20-second cranks, remove the impeller from the raw water pump. This will prevent the muffler from filling with water and backfilling the exhaust line and engine. Once the engine starts, shut it off immediately and re-install the impeller. Re-start the engine and check the exhaust overboard outlet for gushes of water.

### OPERATING

1. Units with Series 3 and Series 4 Control Panels: check gauges often. Oil pressure must be above 15 PSI. The D.C. voltmeter should read between 11 and 15 volts at 80°F (25°C) ambient temperature. The water temperature gauge on Marine sets must be below 200°F (94°C). Normal coolant temperature is 167° to 194°F (75°C to 90°C). Check the A.C. voltage and frequency meters (Series 4 panel). If the gauges deviate from normal levels, shut down the generator set and investigate.
2. Let the unit run unloaded for a three to five minute warm-up period.
3. Apply electrical load.

### STOPPING

1. Remove electrical load from the generator set.
2. Run the engine for a 3 to 5 minute cool down period.
3. Hold the Engine Control switch to the STOP position until the engine comes to a complete stop.
4. Shut off the seacock, fuel valve, and battery switch.

---

## Operating Procedures

---

### SHUTDOWNS AND ALARMS

1. Your unit is fitted with a system to protect it from high water temperature or low oil pressure.
  - a. Generator sets have shutdown systems to stop the engine. They have no warning horns.
  - b. Other alarms and shutdowns are available as optional equipment.

**NOTE:** *Do not rely on your warning to the exclusion of careful gauge monitoring. Watching your gauges can prevent damage to the unit and dangerous power losses.*

2. Do the following when your warning or shutdown system is activated:
  - a. Engage the preheat switch to check the temperature gauge.
  - b. If above 205°F (96°C), use the Trouble Shooting Guide on page 20 to isolate the cause of the overheat.



**CAUTION:** *Do not remove the water fill cap of an overheated engine. Escaping high temperature steam can cause severe burns. Allow the engine to cool and then remove the cap slowly using protective clothing.*

- c. Make repairs. Restart your Marine set after the temperature gauge registers below 200°F (94°C).
  - d. Watch the temperature gauge regularly and turn off the unit if the temperature rises above 205°F (96°C) on units. Repeat troubleshooting.
3. If shutdown is activated and the temperature gauge shows temperature within normal temperature range:
  - a. This shutdown could have happened because of a too high exhaust temperature. This could have been caused by a damaged impeller or a partially blocked sea water strainer. Check the sea water strainer first. If it is clear, then check the condition of the sea water pump impeller.
  - b. Check the engine crankcase oil level.
  - c. If the oil level is low, fill with recommended lubricating oil and restart. Watch the oil pressure gauge carefully and shut off the engine if it does not show a normal reading (20-60 PSI) after a few seconds of operation.
  - d. If the oil level is normal, DO NOT restart the engine. Call your dealer for assistance.

### SPARE PARTS

1. Northern Lights recommends that you keep the following spare parts on hand for field service. The parts are available from your local Northern Lights dealer.

Some marine models already have “On-Board-Kits,” a handy box that contains the most common parts you will need.
2. All owners should have the following spares:
  - a. Primary and secondary fuel filter elements
  - b. Oil filters
  - c. Air filter
  - d. Alternator belt
  - e. Thermostat and gaskets
  - f. Seawater pump impeller & gaskets
  - g. Glow plug
  - h. Injector and washer
3. If your set is operating a long distance from a servicing dealer, add the following:
  - a. Complete set of injectors
  - b. Copper washers for injector change
  - c. Complete set of glow plugs
  - d. Fuel lift pump

## Servicing Schedule Chart

The Servicing Schedule Chart below shows the service schedule required for proper maintenance of your generator set. More detailed coverage of each Service Point (SP) is listed on the page noted in the 'page' column.

**DAILY:**

- SP1 Check oil level in engine
- SP5 Check V-belt tension
- SP7 Check primary fuel filter
- SP13 Check coolant level  
Check sea strainer  
Check raw water pump for leaks
- SP18 Check electrolyte in batteries

**AFTER FIRST 50 HOURS:**

- SP2/3 Change engine oil and filter
- SP6 Adjust valves

**AFTER FIRST 100 HOURS:**

- SP2/3 Change engine oil and filter

**EVERY 250 HOURS:**

- SP2/3 Change engine oil and filter
- SP4 Check air cleaner
- SP19 Check state of charge of batteries

**EVERY 500 HOURS:**

- SP8 Change primary fuel filter element
- SP9 Change secondary fuel filter
- SP22 Inspect condition of exhaust elbow

**EVERY 1000 HOURS:**

- SP4 Change air cleaner element
- SP6 Check valve clearances
- SP11 Check injectors
- SP17 Change impeller

**EVERY 2500 HOURS:**

- SP12 Check fuel injection pump
- SP14 Check and flush cooling system
- SP15 Check and clean heat exchanger

SERVICE POINT	PAGE	OPERATION	DAILY	50 Hours	250 Hours	500 Hours	1000 Hours	2500 Hours
		<b>ENGINE:</b>						
SP1	16	Check oil level	•					
SP2	16	Change engine oil 1) 5)		•	•			
SP3	16	Change lube oil filters 1) 5)		•	•			
SP4	17	Check air cleaner 1) 4)			•			
SP5	17	Check V-belt tension	•					
SP6	17	Check valve clearances 1) 2)					•	
		<b>FUEL SYSTEM:</b>						
SP7	18	Check primary filter (Racor) 2) 3)	•					
SP8	18	Change primary filter element (Racor) 2) 3)				•		
SP9	18	Change secondary fuel filter 1) 3)				•		
SP10	19	Bleed the fuel system 3)						
SP11	20-21	Check injectors 1) 3) 6) 7)					•	
SP12	20	Check fuel injection pump 7)						•
		<b>COOLING SYSTEM:</b>						
SP13	22	Check coolant level	•					
SP14	22	Check and flush cooling system						•
SP15	22	Check and clean heat exchanger						•
SP17	23	Change impeller in raw water pump 1) 3)					•	
SP22		Inspect condition of exhaust elbow 4)				•		
		<b>ELECTRICAL SYSTEM:</b>						
SP18	24	Check electrolyte level in batteries	•					
SP19	24	Check condition of batteries with hydrometer 1) 4)			•			
		<b>DRIVEN EQUIPMENT:</b>						
SP20	24	Clutch and PTO service 2)						
		<b>OUT OF SERVICE:</b>						
SP21	24	Winterizing or out-of-service 3)						

- 1) Perform all maintenance once a year even if hour level has not been reached.
- 2) Consult manufacturer's maintenance schedule, note on chart.
- 3) Whenever necessary.
- 4) More often if necessary.
- 5) After first 50 hours, then at 100 hours, then at every 200 hours.
- 6) Clean injection nozzles every 1500 hours.
- 7) For EPA emission standards fuel nozzle needs to be cleaned every 1500 hours, the fuel nozzle and fuel pump need to be cleaned, adjusted, or repaired every 3000 hours, and the quality guarantee for these parts is 1500 hours or 2 years.

## Servicing

### LUBRICATION - GENERAL

1. Use only clean, high quality lubricants stored in clean containers in a protected area.
2. These lubricants are acceptable:
  - a. API Service CC/CD/CE single viscosity oils.
  - b. API Service CC/CD/CF multi-viscosity oils.
3. Use the proper weight oil for your average operation temperature.

Air Temperature	Single Viscosity	Multi-Viscosity
Above 32°F (0°C)	SAE 30W	SAE 15-40W
-10 to 32°F (-23 to 0°C)	SAE 10W	SAE 10-30W
Below -10°F (-23°C)	SAE 5W	SAE 5-20W

**Figure 4:** Lube Oils

4. Some increase in oil consumption may be expected when SAE 5W and SAE 5-20W oils are used. Check oil level frequently.
5. Never put additives or flushing oil in crankcase.

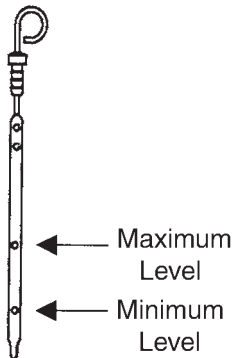

**Figure 5**

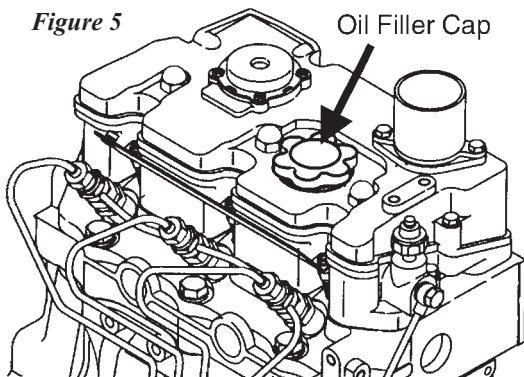

**Figure 6**

### SP-1. CHECKING OIL LEVEL

1. Check the oil level in the crankcase with the dipstick (Fig. 5). The oil level must be in the waffled area on the stick. Never allow the level to go below this area. Follow the lubrication recommendations above.

### SP-2. OIL CHANGES

1. The set is delivered with special break-in oil. Change the engine oil and oil filter after 50 hours of operation. Use diesel-rated break in oil (John Deere pre-packaged or equivalent) during the first 100 hours. Consult your dealer for more information.
2. Change the oil and filter again at 100 hours using the oil recommended in the above diagram. After this, change oil and filter every 250 hours.
3. During intermittent cold weather operation, change oil every 100 hours or six weeks, whichever comes first.
4. Change oil at the end of each season and the beginning of each season.
5. Change oil when engine is warm.
6. Dispose of waste oil in an approved manner.
7. Never use a flushing oil.
8. Loosen the clamp on the oil change tube. Remove cap. Drain oil. Replace the cap and tube.
9. Refill engine with recommended oil for the season.
10. Engine capacity with new oil filter is:

**844W3 and 844LW3 – 2.1 gallons  
(8.2 liters)**

### SP-3. CHANGING LUBE OIL FILTER

1. Change the lube oil filter every 250 hours.
2. Use a filter wrench to remove old filter. Dispose of filter in approved manner.
3. Make sure the gasket from the old filter is removed and discarded. Clean mount face.
4. Spread a thin film of engine oil on the rubber gasket on the new filter and screw it on nipple until gasket meets the sealing surface.
5. Using hands only – no wrench – tighten filter one-half turn farther. Overtightening can do damage to filter housing.
6. Fill engine with recommended oil. Start engine and check for leakage. Stop engine, wait 3 minutes, and check oil level. Add additional oil if necessary.
7. Oil filter part number is:

**844W3 and 844LW3 – #24-03100**

## Servicing

### SP-4. AIR CLEANER

1. Inspect air cleaner every 250 hours. In dusty conditions, check more often.
2. Marine sets: if dirty, wash element in soapy water. Rinse and dry thoroughly before re-installing. Replace if necessary. The element part number is:  
**M844W3 and M844LW3 – #24-23100**
3. C-Series sets: the element cannot be cleaned. Replace it when necessary. Part number is:  
**M20CRW3 – #24-28401**
4. **NOTE: Make absolutely sure no impurities enter the engine while changing the element. Do NOT run the engine with the air cleaner removed.**

### SP-5. V-BELTS

1. Check the tension and wear on the V-belt daily.
2. Use your thumb to press on the belt at the midpoint between the crankshaft and alternator pulleys. The tension is correct if the belt can be depressed about 3/16 in. (5 mm) .

Cylinder	No. 1		No. 2		No. 3		No. 4	
	In	Ex	In	Ex	In	Ex	In	Ex
When No. 1 cyl. is at TDC in compression stroke	○	○	○			○		
With the crankshaft turned by 360° in normal direction from above			○	○			○	○

*Figure 7: 844W3 and 844LW3 Valve sequence*

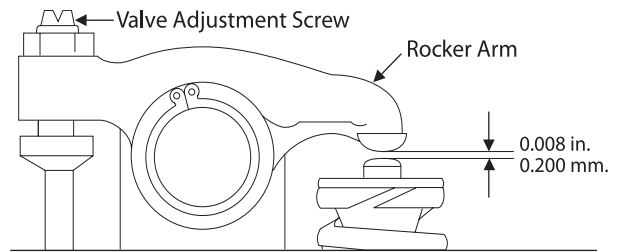

*Figure 8: Valve Adjustment*

### SP-6. VALVE CLEARANCES

1. Adjust valve clearance after 1000 hours or as needed.
2. Valve adjustments should be done after the cylinder head bolts have been re-tightened. Engine should be cold and NOT running.
3. Watch the valves while turning the engine over by hand. Turn until the inlet valve starts to open and the exhaust valve starts to close (the valves are rocking). Then turn the crankshaft one more full turn and adjust the clearance on both valves for this cylinder. Align the top mark of the crank pulley with the top mark of the timing gear case.
4. Loosen the lock nut and adjust the clearance between the rocker arm and valve guide of both the intake and exhaust valves with the adjustment screw (Figure 8). Clearance on both intake and exhaust valves should be 0.008 in. (0.2 mm).
5. Repeat steps 3 and 4 for each cylinder. Each set of valves must be adjusted individually.
6. Replace the rocker arm cover. Tighten cover nuts to 5 - 8 ft/lbs (0.8 - 2.3 kg/m).

## Servicing

### FUELS - GENERAL

1. Use only clean, high quality fuels of the following specifications, as defined by ASTM designation D975 for diesel fuels:
  - a. Use grade no. 2 diesel at ambient temperatures above freezing 32°F (0°C).
  - b. Use grade no. 1 at ambient temperatures below freezing and for all temperatures at an altitude of above 5,500 ft. (1500 meters).
2. Use fuel having less than 1% sulphur (preferably less than 0.5%).
3. The cetane number should be a minimum of 45.
4. DO NOT use these unsuitable grades of fuel:
  - a. Domestic heating oils, all types.
  - b. Class B engine.
  - c. Class D domestic fuels.
  - d. Class E, F, G or H industrial or marine fuels.
  - e. ASTM-D975-60T No. 4-D and higher number fuels.
  - f. Diesel fuel with engine oil mixed in.
5. Do not use any fuel additive other than an authorized diesel fuel biocide if fungus or bacteria cause fuel system problems.
6. Storing fuel:
  - a. Keep dirt, scale, water, and other foreign matter out of fuel.
  - b. Avoid storing fuel for long periods of time.
  - c. Fill the fuel tank at the end of each day's operation. This will reduce condensation and possible biological contamination.
  - d. If biological contamination is detected or suspected, contact your dealer for assistance.

#### Primary Fuel Filter

#### Part Numbers

Complete Unit:  
**24-50002**

Element:  
**24-50012**



*Figure 9: Primary Fuel Filter.*

1. Your generator set should have a primary fuel filter installed. We recommend the Racor brand of fuel filter-water separators.

#### SP-7. PRIMARY FUEL FILTER

- a. Check the primary fuel filter daily as recommended by the filter manufacturer. Empty the collection bowl as necessary.

#### SP-8. PRIMARY FUEL FILTER ELEMENT

- b. Change the element as often as necessary or every 500 hours.
- c. If the bowl fills with water, change the primary and secondary element immediately.

#### SP-9. SECONDARY FUEL FILTER

2. Change secondary fuel filter every 500 hours.  
*NOTE: The fuel filter on the engine is considered the "secondary fuel filter."*
  - a. Remove the spin-on filter by turning it counterclockwise with a filter wrench. Fill the new cartridge with fuel and install it after applying engine oil to gasket surface. Screw on until the gasket surface comes into contact with sealing surface of filter base. Then, tighten it two-thirds of a turn by hand. Do not overtighten.
  - b. Fuel filter part number is:  
**844W3 and 844LW3 – #24-52020**



---

## Servicing

---

### SP-10. BLEEDING THE FUEL SYSTEM



*CAUTION: Escaping diesel fuel under pressure can penetrate skin causing serious personal injury. Before disconnecting lines be sure to relieve all pressure. Before applying pressure, be sure all connections are tight and lines, pipes and hoses are not damaged. Fuel escaping from a very small hole can be almost invisible. Use a piece of cardboard or wood, rather than hands, to search for suspected leaks. If injured by escaping fuel, see a doctor at once. Serious infection or reaction can develop if proper medical treatment is not administered immediately.*

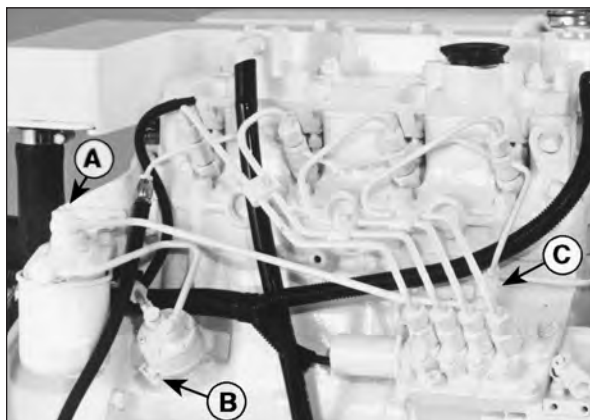

*Figure 10: Fuel System.*

1. The fuel system is self-bleeding. However, any system may need manual bleeding when:
  - a. A new fuel filter is installed;
  - b. The engine has run out of fuel;
  - c. The fuel lines, injection pump or any other fuel system component has been removed and installed.
2. Loosen bleed bolt “A” (Figure 10) on top of the filter. Pump hand primer “B” on fuel lift pump until pure fuel (no bubbles) escapes from bleed bolt “A”. Tighten bleed screw “A”.
3. Loosen bleed screw “C”. Pump hand primer “B” until pure fuel (no bubbles) escapes. Then tighten bleed screw “C”.
4. If the engine does not start after the above bleeding process, loosen a fuel line at the injector while cranking the engine with the starter motor until pure fuel escapes. Then tighten the connection. Do each line **one-at-a-time**.
5. After the engine has started, use a piece of cardboard to look for fuel leaks.

---

## Servicing

---

### SP-11. INJECTOR SERVICE

1. Injectors should be checked every 1000 hours. Check should be made by a Northern Lights dealer or local injection repair station. Have your dealer check the fuel injection nozzle spray pattern with injection nozzle tester. If the starting pressure is too high or the spray pattern is off, abnormal fuel combustion could take place causing low engine output and black exhaust smoke.



**CAUTION:** *Escaping diesel fuel under pressure can have sufficient force to penetrate the skin causing serious personal injury. If injured by escaping diesel fuel, see a doctor at once.*

#### 2. Injector removal:

- a. Clean loose dirt from around the injectors and the fuel lines.
- b. Relieve high pressure in the fuel lines by loosening the delivery line flare nuts at each injector (Figure 11).
- c. Remove delivery lines by disconnecting from injectors and injection pump (Figure 12). Remove all lines as an assembly; do not remove the spacers. Cover the ends of the lines, the injector inlets and injection pump outlets to keep dirt out (Figure 13).
- d. Remove the return line retaining bolts (Figure 14). Remove the return line (Figure 15).
- e. Unscrew and remove the injectors (Figure 16).  
**NOTE:** *Do not use pry bars to remove injectors from cylinder head.*
- f. After removing the injectors, discard the copper sealing washers from the injector hole in the head (Figure 17). Cover holes to prevent dirt and debris from entering the cylinders.

#### 3. Injector installation:

- a. Install a new copper sealing washer in each injector hole (Figure 17).
- b. Screw in injector and tighten to 44 - 51 ft/lbs (6 to 7 kgm) (Figure 18).  
**NOTE:** *Overtightening can damage injector.*
- c. Install return line using a new sealing washer below each connection. Tighten return line retaining bolts to 22 - 30 ft/lbs.
- d. Install delivery lines. Leave loose at injectors for bleeding.
- e. Crank engine to fill lines. Tighten lines at injectors to 11-18 ft./lbs. Start engine and check

for leaks using a piece of paper or cardboard.

**DO NOT use hand to check for leaks.**

### SP-12. INJECTION PUMP

1. Since operating conditions may vary considerably, it is difficult to give a definite interval for checking the injection pump. But as a rule, pump settings, maximum speed, idle speed and exhaust smoke should be checked after every 2500 hours of operation. Service of the fuel injection pump should only be done if checks indicate pump malfunction.
2. Black smoke can be an indication of pump malfunction. Before servicing the pump, check other possible causes:
  - a. Check cleanliness of air filter.
  - b. Check valve clearances.
  - c. Clean and check injectors.
3. Any repair which involves disassembly of the injection pump must be carried out by specially trained mechanics with the proper tools and test equipment.

**NOTE:** *All warranties on the engine become null and void if the injection pump seals are broken by unauthorized persons.*

## Servicing

*For illustration purposes only, your specific model may not be shown*



**Figure 11:** Remove delivery line flare nuts.



**Figure 15:** Remove return line.

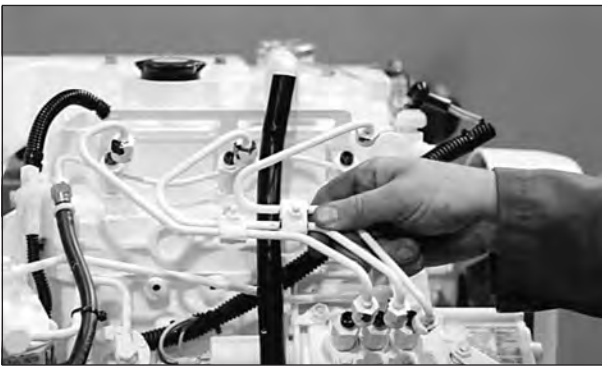

**Figure 12:** Remove delivery lines.



**Figure 16:** Unscrew injector.



**Figure 13:** Cover lines, inlets and injection pump outlets.



**Figure 17:** Remove and replace copper sealing washer.



**Figure 14:** Remove return line nuts.



**Figure 18:** Reinstall injector. Torque to proper tightness.

## Servicing

### COOLING SYSTEM - GENERAL

**NOTE:** *Marine sets – be sure to close the sea-cock before working on the engine cooling system.*



**CAUTION:** *The cooling water in the engine reaches extremely high temperatures. You must use extreme caution when working on hot engines to avoid burns. Allow the engine to cool before working on the cooling system. Open the filler cap carefully, using protective clothing when the engine is warm.*

### WATER QUALITY

1. Distilled, deionized, soft water is preferred for use in cooling systems. Bottled distilled water from a food store or water supplier is recommended. Tap water often has a high mineral content. Tap water should NEVER be put in a cooling system unless first tested by a water quality laboratory. Do not use water made by the reverse osmosis method unless it has been PH neutralized.
2. Here are acceptable water quality specifications:

Contaminates	Parts per Million	Grains per Gallon
Maximum Chlorides	40	2.5
Maximum Sulfates	100	5.9
Maximum Dissolved Solids	340	20.0
Maximum Total Hardness	170	10.0
PH Level 5.5 to 9.0		

3. If chlorides, sulfates or total dissolved solids are higher than the above given specification, the water must be distilled, demineralized, or deionized before it is used in a cooling system.
4. If total hardness is higher than 170 ppm and all other parameters are within the given specifications, the water must be softened before it is used to make coolant solution.

### SP-13. CHECK THE COOLANT LEVEL

1. Check the coolant level each day before starting the engine. Check the water level by removing the pressure cap from the expansion tank.  
In order to give the cooling water an opportunity to expand, the level should be about 1 in. (2.5 cm) below the filler cap sealing surface when the engine is cold.
2. The pressure valve in the filler cap releases when the pressure is approximately 7 PSI (0.5 bar). Use a cap pressure tester to check cap if you suspect it is faulty.

### SP-14. COOLING SYSTEM FLUSHING

1. Flush the cooling system every 2500 hours.
2. Marine sets:
  - a. Remove expansion tank cap and drain engine block.
  - b. Open block drain cock. Remove hose from bottom of heat exchanger tank.
  - c. Pour clean water into expansion tank until water coming from drains is free of discoloration and sediment. Let water drain completely. Close drains and refill with recommended mixture.
3. Coolant Specifications:  
Use 50% distilled water / 50% ethylene glycol antifreeze mix. Antifreeze mixture is recommended as a good year-round coolant.
4. Check hoses and connections and repair any leakage.

### SP-15. HEAT EXCHANGER

1. Clean the heat exchanger core after 2500 hours of operation.
2. Drain expansion tank and heat exchanger.
3. Remove heat exchanger end covers and remove core.
4. Clean the inside of exchanger core tubes using a metal rod. Flush, inspect and clean again if necessary.
5. Reassemble. Fill the cooling system, start the engine and check for leaks.

## Servicing

### SP-17. RAW WATER PUMP

1. Change the seawater pump impeller every 1000 hours, or as needed.
2. Remove the pump end cover. Pry out the impeller using needle-nose pliers or two screwdrivers. Be sure you remove all pieces of failed impeller.  
**NOTE: Place some kind of protection under the screwdrivers in order not to damage the pump housing. If the impeller has broken into pieces, remove front heat exchanger end cover and inspect for impeller pieces. Clean inlet to heat exchanger bundle and reassemble.**
3. Clean the inside of the housing.
4. Press in the new impeller and place the sealing washers in the outer end of the impeller center if this has not already been done.
5. Replace the cover using a new gasket.  
**NOTE: Make sure that there is always an extra impeller and cover gasket in reserve on board.**

### GENERATOR ENDS

The maintenance and operation recommendations for the generator end are in a separate Owner's Manual. If you do not have one of these manuals, contact your local Northern Lights dealer.

### ELECTRICAL SYSTEM - GENERAL

1. Never switch battery switch off or break the circuit between the alternator and batteries while the engine is running. Regulator damage can result.
2. Do NOT reverse the polarity of battery cables when installing the battery.
3. If welding on the unit, disconnect the regulator and battery. Isolate the leads.
4.  Disconnect the battery cables when servicing the D.C. alternator.
5. Never test with a screwdriver, etc., against any terminal to see if it emits sparks.
6. Do not polarize the alternator or regulator.
7. A D.C. circuit breaker protects your control panel and wiring harness. It is located in the side of the generator junction box.

### GLOW PLUGS

1. Each cylinder is supplied with a glow plug which serves to heat the combustion chamber.
2. To check the glow plugs, loosen the current carrying flat wire between the plus-poles of the glow plugs (Figure 19). Connect a D.C. test bulb between the plus-pole of the battery and the plus-pole of the glow plug. If the bulb lights up, the glow plug is functioning properly.
3. Check all glow plugs and replace any that are faulty.

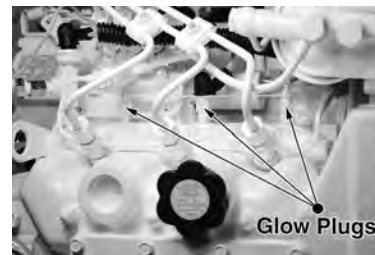

Figure 19: Glow plugs.



---

## Servicing

---

### BOOSTER BATTERIES

**CAUTION:** Battery gas can explode.

*Keep all flames and sparks away from batteries.*

1. Before changing or using booster batteries, check battery electrolyte level. Add distilled water if necessary.
2. Booster and main batteries must have the same voltage rating.
3. First, connect positive (+) terminal of booster battery to positive (+) terminal of main battery. Then, connect negative (-) terminal of booster battery to ground on the engine block (see Figure 20).
4. Remove booster battery after starting engine.
5. Sealed batteries: See manufacturer charging and booster instructions.

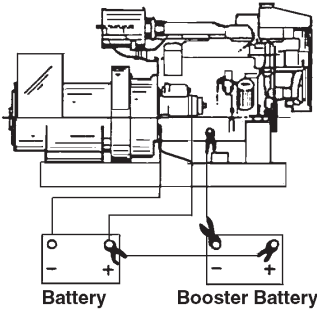

**Figure 20:**  
Battery connections.

### BATTERY CARE

#### SP-18. CHECK ELECTROLYTE LEVELS

1. Check electrolyte level daily. Add distilled water to manufacturer's recommended level.

#### SP-19. CHECK CABLES AND TERMINALS

2. Batteries, cables and cable terminals should be checked and cleaned every 100 hours. Clean corrosion with a water and baking soda solution. Flush with clean water. Tighten terminals and grease them to inhibit corrosion.
3. Check the battery condition with a hydrometer every 250 hours.

#### SP-20. P.T.O.

1. The electric clutch P.T.O. does not have any scheduled maintenance points. However, the equipment the P.T.O. powers may require maintenance. Consult the manufacturer of the driven equipment.

#### SP-21. WINTERIZING / OUT-OF-SERVICE

If the generator set will not be used for more than 3 months the following preparations should be taken for long term storage.

- Change engine oil and filter, using API CJ or CK-4, 15W-40 oil.
- Run the engine up to at least 140° F from a small, clean source of fuel dosed with either "Stab-il" brand fuel system stabilizer (diesel engine formula), or Stanadyne Performance fuel system conditioner. If neither of these fuel treatments is available, you may also use John Deere fuel system conditioner.
- Completely drain, flush, and fill the cooling system with pre-mixed, 50/50, conventional ethylene-glycol heavy-duty diesel engine coolant (with SCAs).
- Loosen alternator drive belt.
- Completely seal off intake and exhaust openings with heavy plastic bags and duct tape.
- Cover entire engine in large plastic bag and tape closed at bottom of bag-place several moisture absorbing desiccant packs inside plastic bag. Store engine in original shipping crate, if possible, or other suitable storage crate.
- Store engine inside a building (preferably climate controlled) to prevent corrosion.

To Remove Generator Set from Long-Term Storage:

1. Take off all protective coverings and unseal all the openings that were covered up.
2. Install batteries that are fully charged and connect the terminals.
3. Install the fan and alternator belts if they had been removed.
4. Fill the fuel tank.
5. Perform all pre-start checks.
6. Crank the engine for 20 seconds with the starter, without letting the engine start. Wait 2 minutes and crank the engine an additional 20 seconds to make sure all bearing surfaces are well coated.
7. Start the engine and run at no load in a low idle for several minutes. Make sure the engine is warmed up and check gauges before going under load.
8. Check all gauges and check for leaks.



## Troubleshooting

### DC ELECTRICAL SYSTEM

PROBLEM	POSSIBLE CAUSE	RECOMMENDATION(S)
<b>Battery Will Not Charge</b>	Loose or corroded connections	• Clean and tighten battery connections.
	Sulfated or worn out batteries	• Check specific gravity of each battery. • Check electrolyte level of each battery.
	Loose or defective alternator belt	• Adjust belt tension. • Replace belt.
<b>Starter Inoperative</b>	Check DC circuit breaker	• If the breaker is tripped, reset it.
	Loose or corroded connections	• Clean and tighten loose battery and harness plug connection.
	Low battery output	• Check specific gravity of each battery. • Check electrolyte level of each battery.
	Defective electrical system ground wire:	• Repair or replace.
<b>Starter Cranks Slowly</b>	Low battery output	• Battery is too small. • Battery cables are too small.
	Check specific gravity of each battery	• Replace battery if necessary.
	Check electrolyte level of each battery	• If low, fill cells with distilled water.
	Crankcase oil too heavy	• Fill with oil of appropriate viscosity.
	Loose or corroded connections	• Clean and tighten loose connections.
<b>Entire Electrical System Does Not Function</b>	Check DC circuit breaker	• If breaker is tripped, reset it.
	Faulty connection	• Clean and tighten battery and harness plug connections.
	Sulfated or worn out batteries	• Check specific gravity and electrolyte level of each battery.

If you cannot correct problems with these procedures, see your **Northern Lights** dealer.

## Troubleshooting

### ENGINE

PROBLEM	POSSIBLE CAUSE	RECOMMENDATION(S)
<b>Engine Hard to Start or Will Not Start</b>	Improper starting procedure	<ul style="list-style-type: none"> <li>• See starting section of this manual. Take special note of Bypass Switch operation.</li> </ul>
	No fuel	<ul style="list-style-type: none"> <li>• Check level of fuel in fuel tank.</li> </ul>
	Low battery output	<ul style="list-style-type: none"> <li>• Check electrolyte level and condition.</li> </ul>
	Excessive resistance in starting circuit	<ul style="list-style-type: none"> <li>• Clean and tighten all battery connections.</li> </ul>
	Crankcase oil too heavy	<ul style="list-style-type: none"> <li>• Use oil of proper viscosity.</li> </ul>
	Improper type of fuel	<ul style="list-style-type: none"> <li>• Consult fuel supplier and use proper type of fuel for operating condition.</li> </ul>
	Water, dirt or air in fuel system	<ul style="list-style-type: none"> <li>• Drain, flush, fill and bleed system.</li> </ul>
	Clogged primary fuel filter element	<ul style="list-style-type: none"> <li>• Clean or replace filter element.</li> </ul>
	Lift pump malfunction	<ul style="list-style-type: none"> <li>• Repair lift pump.</li> </ul>
	Clogged secondary fuel filter element	<ul style="list-style-type: none"> <li>• Replace filter element.</li> </ul>
<b>Engine Runs Irregularly or Stalls Frequently</b>	Dirty or faulty injection nozzles	<ul style="list-style-type: none"> <li>• Have your dealer check injection nozzles.</li> </ul>
	Below normal engine temperature	<ul style="list-style-type: none"> <li>• Remove and check thermostat.</li> </ul>
	Clogged primary fuel filter element	<ul style="list-style-type: none"> <li>• Clean or replace filter element.</li> </ul>
	Clogged secondary fuel filter element	<ul style="list-style-type: none"> <li>• Replace secondary filter element.</li> </ul>
	Water or dirt in the fuel system	<ul style="list-style-type: none"> <li>• Drain, flush, fill and bleed system.</li> </ul>
	Dirty or faulty injection nozzles	<ul style="list-style-type: none"> <li>• Have your dealer check injection nozzles.</li> </ul>
	Air in fuel system	<ul style="list-style-type: none"> <li>• Inspect clamps and hoses on suction side of fuel pump for air leak.</li> </ul>
	Control lever adjusted incorrectly	<ul style="list-style-type: none"> <li>• Adjust control lever</li> </ul>
	Improper type of fuel	<ul style="list-style-type: none"> <li>• Consult fuel supplier and use proper type of fuel for operating condition.</li> </ul>
Uneven compression pressure between cylinders.	<ul style="list-style-type: none"> <li>• Check cylinder compression pressure.</li> </ul>	
<b>Lack of Engine Power</b>	Intake air restriction	<ul style="list-style-type: none"> <li>• Service air cleaner, check proper ventilation.</li> </ul>
	Clogged primary fuel filter element	<ul style="list-style-type: none"> <li>• Clean or replace filter element.</li> </ul>
	Clogged secondary fuel filter element	<ul style="list-style-type: none"> <li>• Replace filter element.</li> </ul>
	Injection pump not getting fuel	<ul style="list-style-type: none"> <li>• Have injection pump checked.</li> </ul>
	Improper type of fuel	<ul style="list-style-type: none"> <li>• Consult fuel supplier and use proper type of fuel for operating conditions.</li> </ul>

## Troubleshooting

### ENGINE

PROBLEM	POSSIBLE CAUSE	RECOMMENDATION(S)
<b>Lack of Engine Power</b>		
<i>(continued)</i>		
	Overheated engine	• See “Engine Overheats” in next category.
	Below normal engine temperature	• Remove and check thermostat.
	Improper valve clearance	• Reset valves. Best done by dealer.
	Dirty or faulty injection nozzles	• Replace injectors. Best done by dealer. • See your local dealer.
	Poor cylinder compression pressure	• Check bore for wear, or check alignment of nozzle holder. Re-adjust valve clearance.
<hr/>		
<b>Engine Overheats</b>		
	Low coolant level	• Fill tank or radiator to proper level, with proper mixture of coolant. • Check hoses for loose connections and leaks.
	Air cleaner element clogged	• Clean or replace.
	Keel cooling tubes have been painted (marine)	• Remove paint from tubes.
	Cooling system interior dirty	• Flush cooling system.
	Defective thermostat	• Remove and check thermostat.
	Defective temperature gauge	• Check water temperature with thermometer and replace gauge if necessary.
	Water pump impeller worn/broken	• Check impeller and replace if necessary.
	V belts slipping	• Fix belts to proper tension.
<hr/>		
<b>Engine Knocks</b>		
	Insufficient oil	• Call your dealer.
	Injection pump out of time	• Call your dealer.
	Below normal engine temperature	• Check your thermostats. • Check water temperature to see if temperature gauge is working properly.
	Engine overheating	• See “Engine Overheating” section.
<hr/>		
<b>High Fuel Consumption</b>		
	Improper type of fuel	• Use correct fuel for temperature.
	Clogged or dirty air cleaner	• Service air cleaner.
	Improper valve clearance	• See your dealer.
	Injection nozzles dirty	• See your dealer.
	Injection pump out of time	• See your dealer.
	Engine not at proper temperature	• Check your thermostats. • Check water temperature with thermometer and replace gauge if necessary.

If you cannot correct problems with these procedures, see your **Northern Lights** dealer.

## Troubleshooting

### ENGINE

PROBLEM	POSSIBLE CAUSE	RECOMMENDATION(S)
<b>High Fuel Consumption</b> <i>(continued)</i>	Fuel leakage	• Improper installation or tightening.
	Excessive load on engine	• Check loads.
<b>Below Normal Engine Temperature</b>	Thermostat not working properly	• Check thermostat.
	Temperature gauge not working properly	• Check water temperature with thermometer.
<b>Engine Malfunctions at High Output Range</b>	Fuel supply insufficient	• Air in fuel system or clogged fuel filter element
	Fuel injection amount between plungers uneven	• Check fuel injectors
	Valve clearance adjusted incorrectly	• Re-adjust valve clearances
	Valve spring broken	• Replace valve spring
	Governor spring broken	• Replace governor spring
<b>Low Oil Pressure</b>	Low oil level	• Fill crankcase to proper level.
	Improper type of oil	• Drain and fill crankcase with correct oil.
	Partially plugged oil filter	• Replace filter. Check bearings, oil pump, and relief valve for wear.
<b>High Oil Consumption</b>	Break-in period	• Oil consumption decreases after break in.
	Crankcase oil too light	• Use proper viscosity oil.
	Oil leaks	• Check for leaks in lines around gaskets and drain plug.
<b>Engine Emits Black or Gray Exhaust Smoke</b>	Clogged or dirty air cleaner	• Service air cleaner.
	Defective muffler (back pressure too high)	• Have dealer check back pressure.
	Improper fuel	• Use correct fuel for temperature.
	Injection nozzles dirty	• See your dealer.
	Engine timing off	• See your dealer.
<b>Engine Emits White Smoke</b>	Improper fuel	• Use correct fuel for temperature.
	Cold engine	• Warm up engine to normal operating temperature.
	Defective thermostat	• Remove and check thermostat.
	Engine timing off	• See your dealer.

If you cannot correct problems with these procedures, see your **Northern Lights** dealer.

## AC Wiring Diagrams

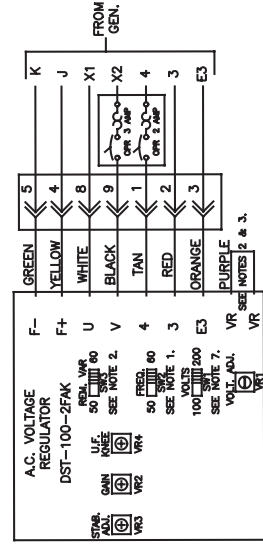
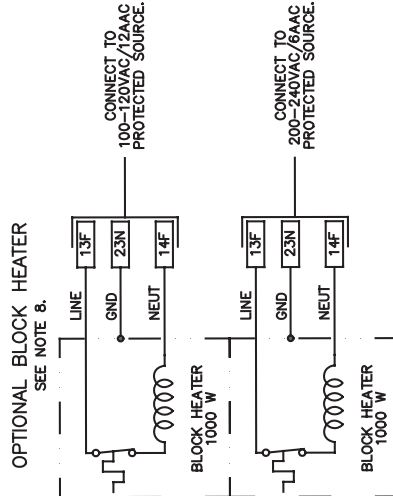
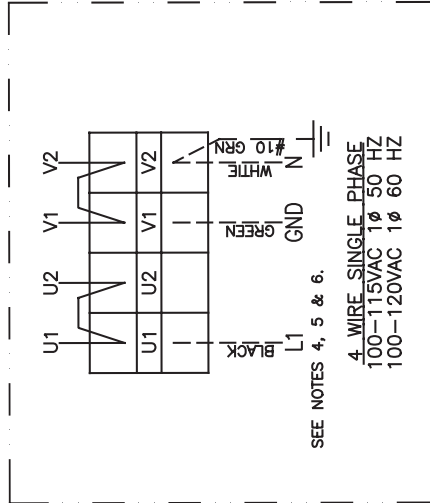
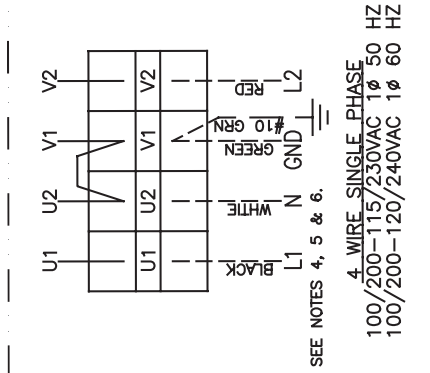
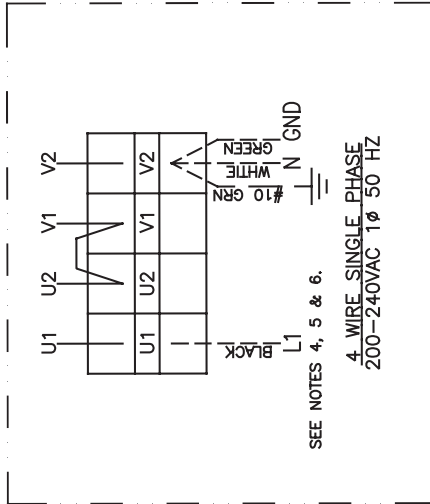

- NOTES:**
1. SET SW2 FOR CURRENT APPLICATION, (50 OR 60 HZ.).
  2. SET SW3 PER APPLICATION IF REMOTE VOLTAGE ADJUST RHEOSTAT IS USED.
  3. FOR REMOTE VOLTAGE ADJUST RHEOSTAT CUT JUMPER AND SPLICE INTO PURPLE LEADS.
  4. TERMINAL BLOCKS WILL NOT ACCOMMODATE LARGER GAUGE CONDUCTORS. IF REQUIRED, REMOVE AFFECTED LEADS FROM TERMINAL BLOCK(S) AND MAKE CONNECTIONS USING BOLT, LOCK WASHER AND NUT. ISOLATE BY WRAPPING WITH ELECTRICAL TAPE.
  5. MARINE GENSSETS ARE GROUNDED BY CUSTOMER. AT CUSTOMER'S DISCRETION, INDUSTRIAL GENSSETS ARE TO BE GROUNDED IN ACCORDANCE WITH THE NATIONAL ELECTRICAL CODE AND ANY APPLICABLE LOCAL CODES. HIDDEN (DASHED) LINES INDICATE CUSTOMER SUPPLIED AND CONNECTED MAIN OUTPUT CONDUCTORS. SIZING TO BE DETERMINED PER INSTALLATION.
  7. AVR INPUT SENSING SWITCH SW1 IS TO BE SET TO THE 200V POSITION FOR ALL VOLTAGES EXCEPT 100-120VAC APPLICATIONS.
  8. DO NOT ENERGIZE HEATER WHEN UNIT IS IN OPERATION.

**AC Wiring Diagram**  
Taiyo PX300K2 4 Lead Generator  
with DST-100-2FAK AVR  
Drawing B-9724E

# AC Wiring Diagrams

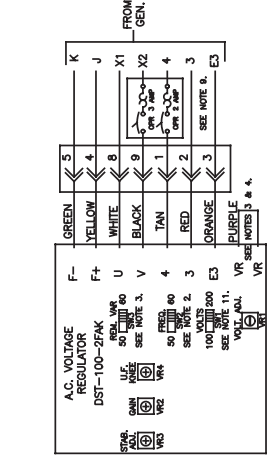
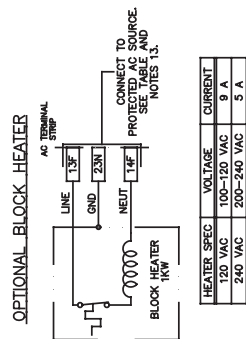
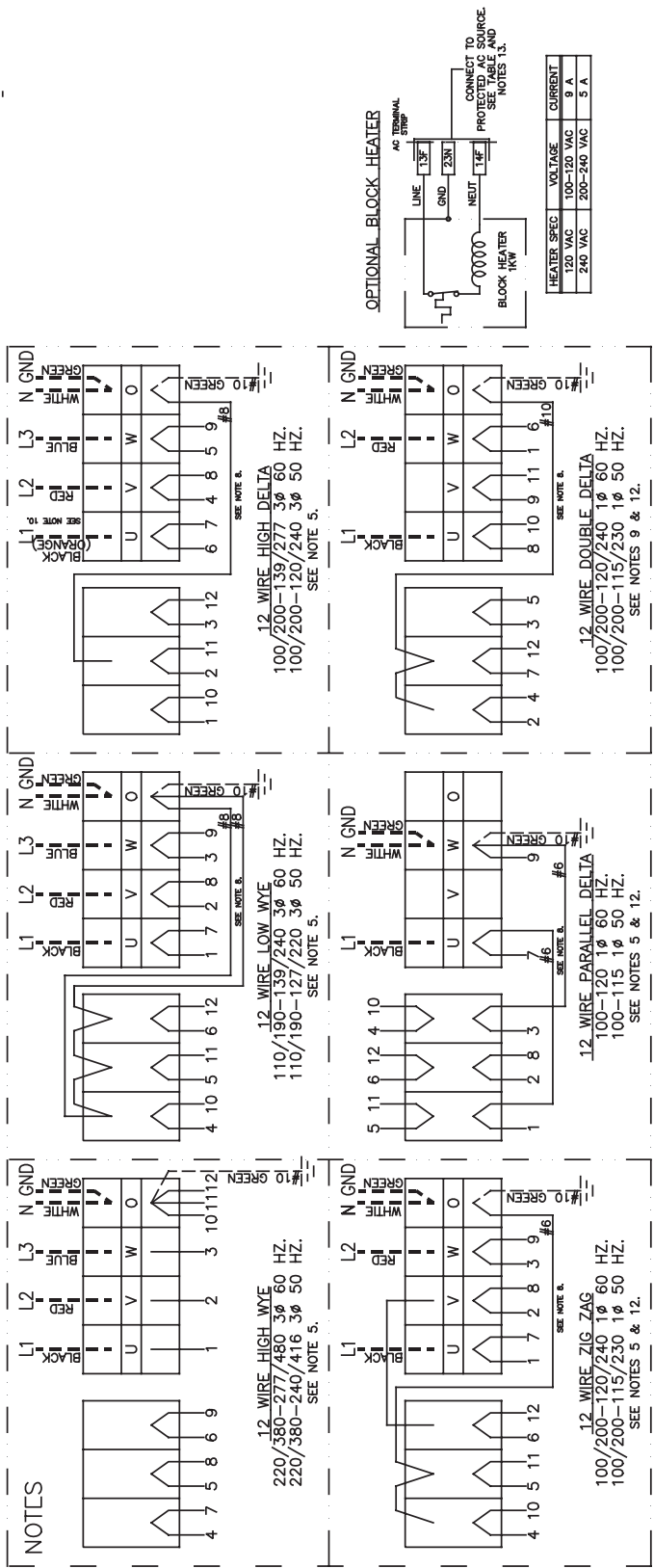

- NOTES:**
1. ALL NU INSTALLED CONDUCTORS ARE TO BE TYPE MTW, 105°C, STRANDED, 600VAC.
  2. SET SW2 FOR CURRENT APPLICATION, (50 OR 60 HZ).
  3. SET SW3 PER APPLICATION IF REMOTE VOLTAGE ADJUST IS USED.
  4. REMOVE THE NEUTRAL JUMPER FROM THE MAIN DISTRIBUTION PANEL.
  5. DELETE NEUTRAL CONDUCTOR (AND JUMPER IF PRESENT) IF LOWER VOLTAGE IS NOT REQUIRED.
  6. MARINE GENSETS ARE GROUNDED BY CUSTOMER, AT CUSTOMER'S DISCRETION, INDUSTRIAL GENSETS ARE TO BE GROUNDED IN ACCORDANCE WITH THE NATIONAL ELECTRICAL CODE AND ANY APPLICABLE LOCAL CODES.
  7. THICK HIDDEN (DASHED) LINES INDICATE CUSTOMER SUPPLIED AND CONNECTED MAIN OUTPUT CONDUCTORS.
  8. NEUTRAL CONDUCTORS SIZE FOR LOADS AT THE LOWEST LISTED VOLTAGE. CONSULT N.E.C. ENGINEERING TO DETERMINE INSULATION RATING.
  9. FOR CONDUCTOR SIZING AT OTHER GENSET VOLTAGE/KW RATINGS, DISCONNECT LEADS 3 AND 4 FROM AVR. CONNECT LEAD 3 TO AVR TERM. 4 (THROUGH C.B.), CONNECT LEAD 4 TO AVR TERM. 3. THE DOUBLE DELTA CONFIGURATION REQUIRES THE AVR TO BE REMOVED AS FOLLOWS: DISCONNECT LEADS 3 AND 4 FROM AVR. CONNECT LEAD 3 TO AVR TERM. 4 (THROUGH C.B.), CONNECT LEAD 4 TO AVR TERM. 3. DISCONNECT LEAD E3 FROM AVR AND ISOLATE. CONNECT AVR TERMINAL E3 TO MAIN OUTPUT BLOCK TERM. "W".
  10. NEUTRAL (HIGH LEG) TO BE MARKED ORANGE WHEN NEUTRAL IS PRESENT, IN ACCORDANCE WITH ARTICLE 215-8 OF THE NATIONAL ELECTRICAL CODE.
  11. AVR INPUT SENSING SWITCH SW1 IS TO BE SET TO THE 200V POSITION FOR ALL VOLTAGES EXCEPT 100-120VAC APPLICATIONS.
  12. THE WIRING IS FOR MODEL M303K3 ONLY.
  13. DO NOT ENERGIZE HEATER WHEN UNIT IS IN OPERATION.

**AC Wiring Diagram**  
 Taiyo PX300K2 12 Lead Generator  
 with DST-100-2FAK AVR  
 Drawing B-9723D











# DC Wiring Diagrams

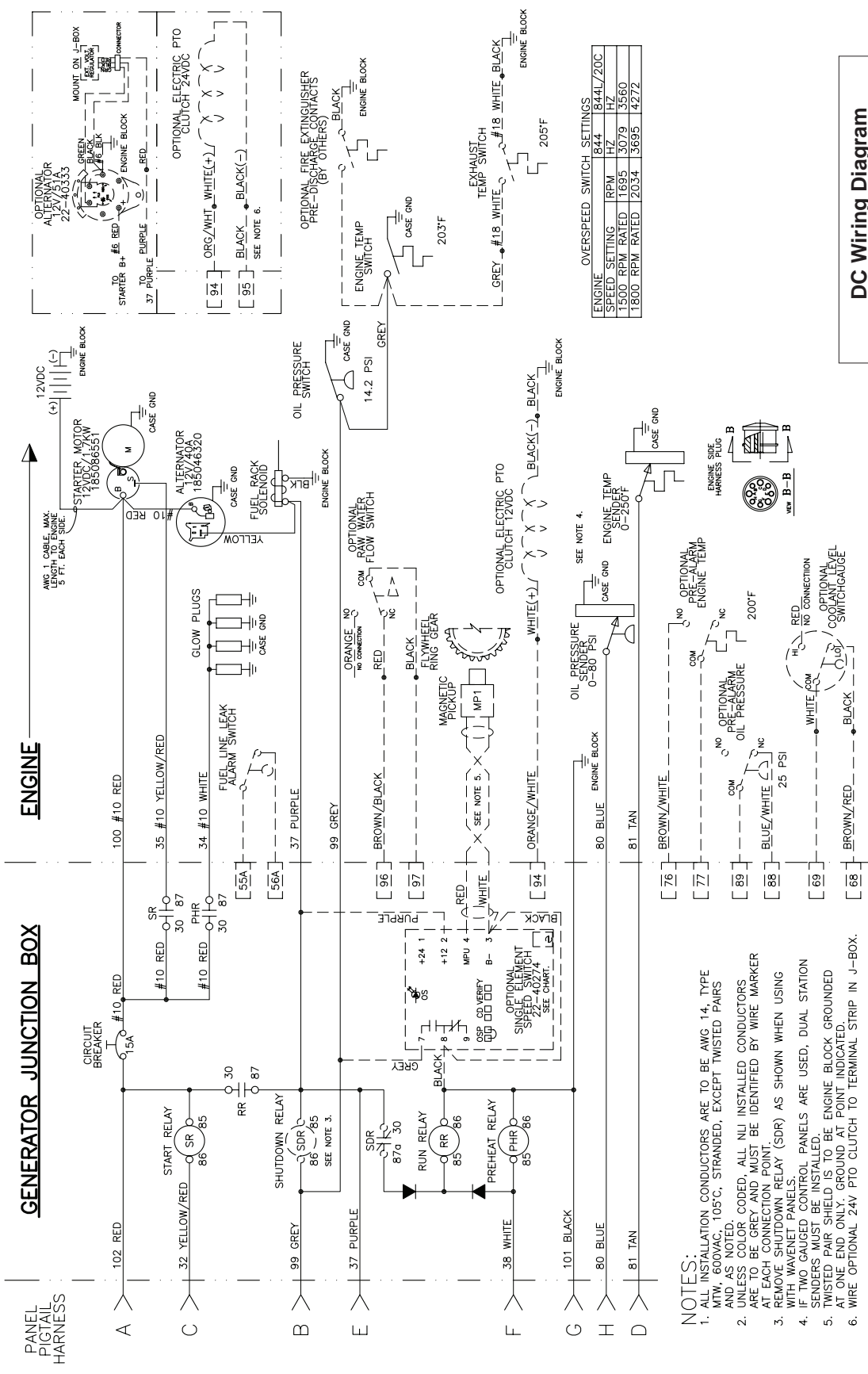

**DC Wiring Diagram**  
M844, M20CRW  
for 12 VDC Standard Ground  
Drawing B-9902B





# DC Wiring Diagrams

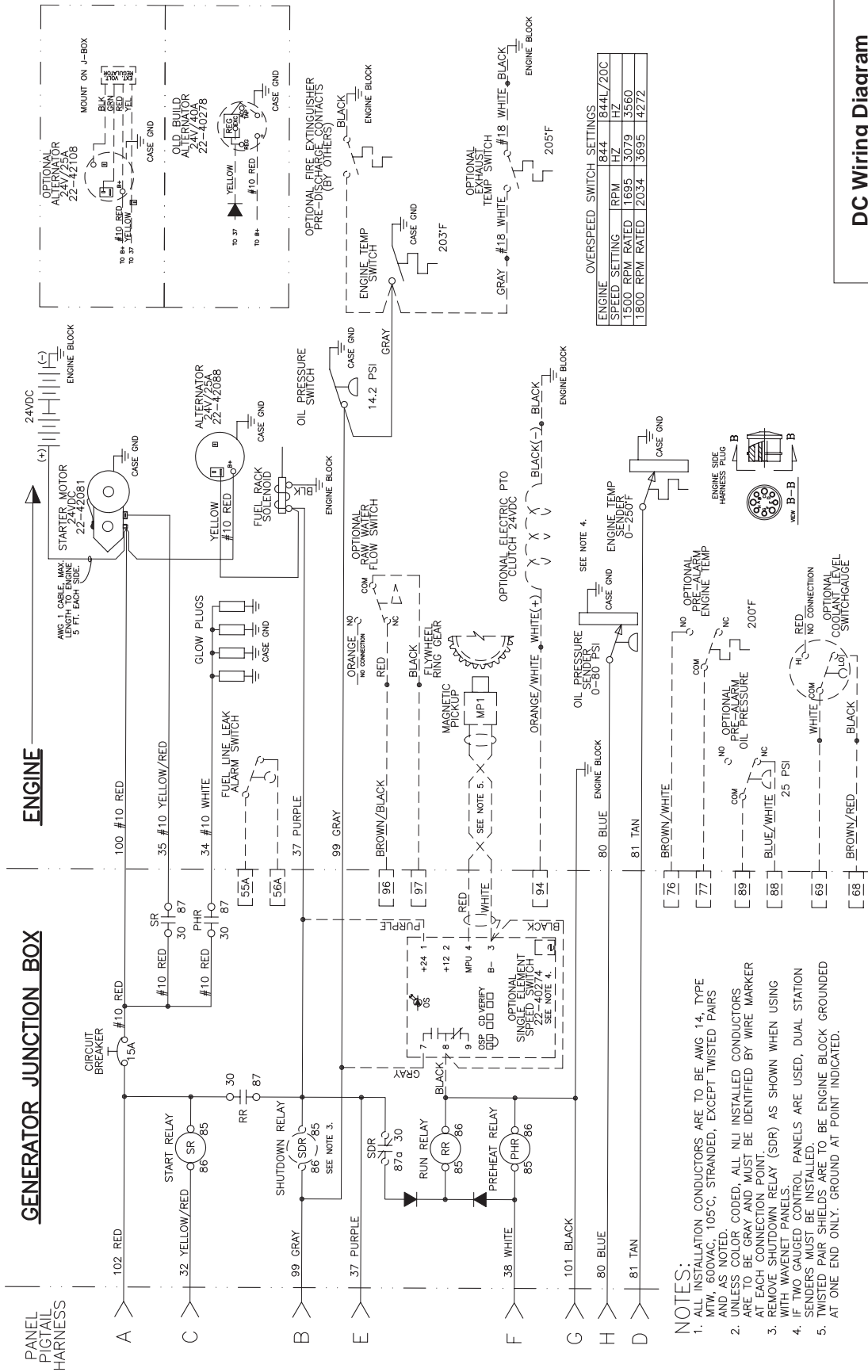

**DC Wiring Diagram**  
M844W, M20CRW  
for 24 VDC Standard Ground  
Drawing B-9907C

- NOTES:**
1. ALL INSTALLATION CONDUCTORS ARE TO BE AWG 14, TYPE MTW, 600VAC, 105°C, STRANDED, EXCEPT TWISTED PAIRS AND AS NOTED.
  2. UNLESS COLOR CODED, ALL NUJ INSTALLED CONDUCTORS ARE TO BE GRAY AND MUST BE IDENTIFIED BY WIRE MARKER AT EACH CONNECTION POINT.
  3. REMOVE SHUTDOWN RELAY (SDR) AS SHOWN WHEN USING WITH WAVENET PANELS.
  4. IF TWO GAUGED CONTROL PANELS ARE USED, DUAL STATION SENDERS MUST BE INSTALLED.
  5. TWISTED PAIR SHIELDS ARE TO BE ENGINE BLOCK GROUNDED AT ONE END ONLY. GROUND AT POINT INDICATED.

# DC Wiring Diagrams

**DC Wiring Diagram**  
 M844W, M20CRW  
 for 24 VDC Isolated Ground S-1B  
 Drawing B-9906B

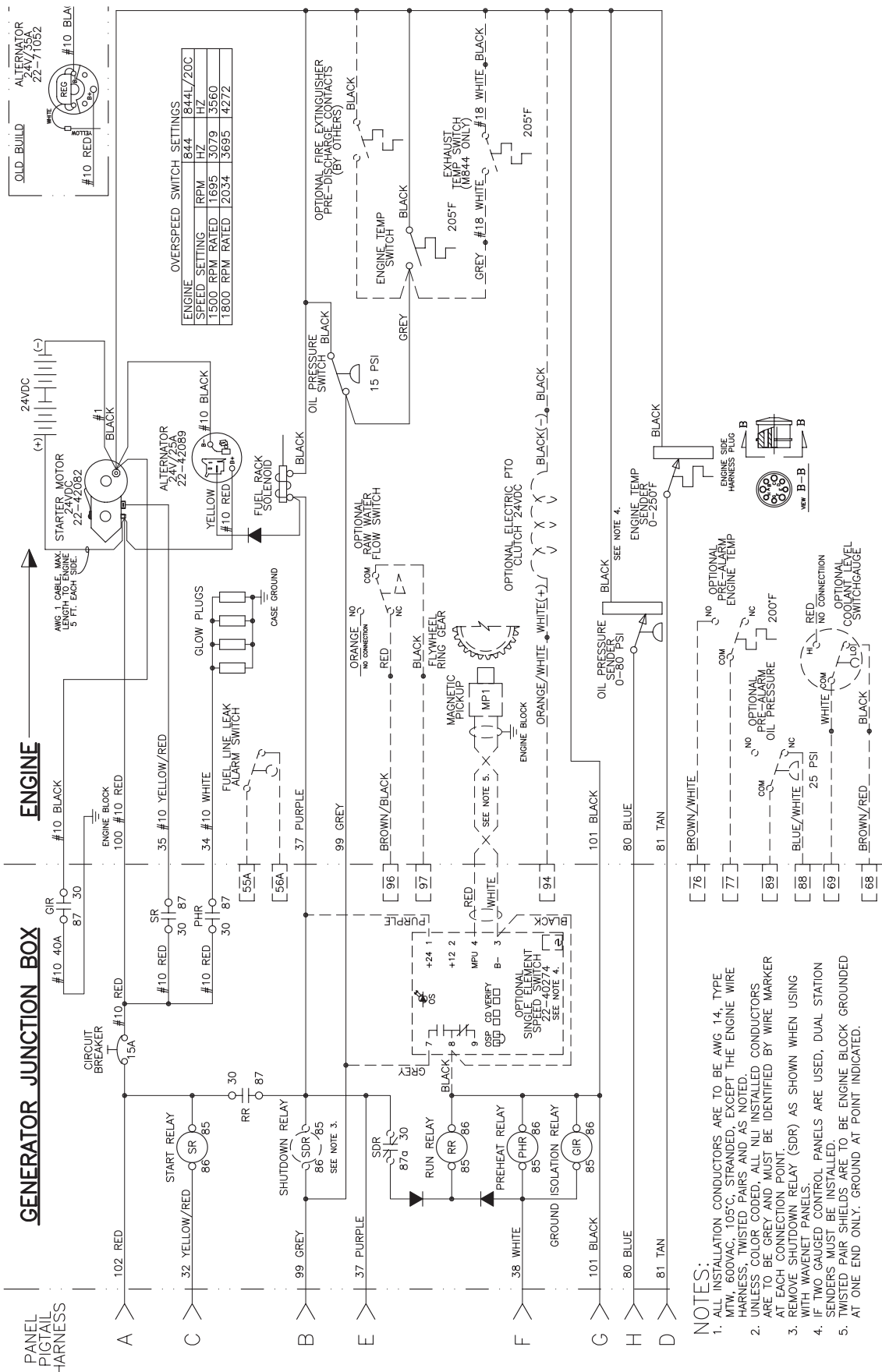

- NOTES:**
1. ALL INSTALLATION CONDUCTORS ARE TO BE AWG 14, TYPE MW, 600VAC, 105°C, STRANDED, EXCEPT THE ENGINE WIRE HARNESS, TWISTED PAIRS AND AS NOTED.
  2. UNLESS COLOR CODED, ALL NLI INSTALLED CONDUCTORS ARE TO BE GREY AND MUST BE IDENTIFIED BY WIRE MARKER AT EACH CONNECTION POINT.
  3. REMOVE SHUTDOWN RELAY (SDR) AS SHOWN WHEN USING WITH WAVEUNIT PANELS.
  4. IF TWO GAUGED CONTROL PANELS ARE USED, DUAL STATION SENDERS MUST BE INSTALLED.
  5. TWISTED PAIR SHIELDS ARE TO BE ENGINE BLOCK GROUNDED AT ONE END ONLY. GROUND AT POINT INDICATED.

## Panel Wiring Diagrams

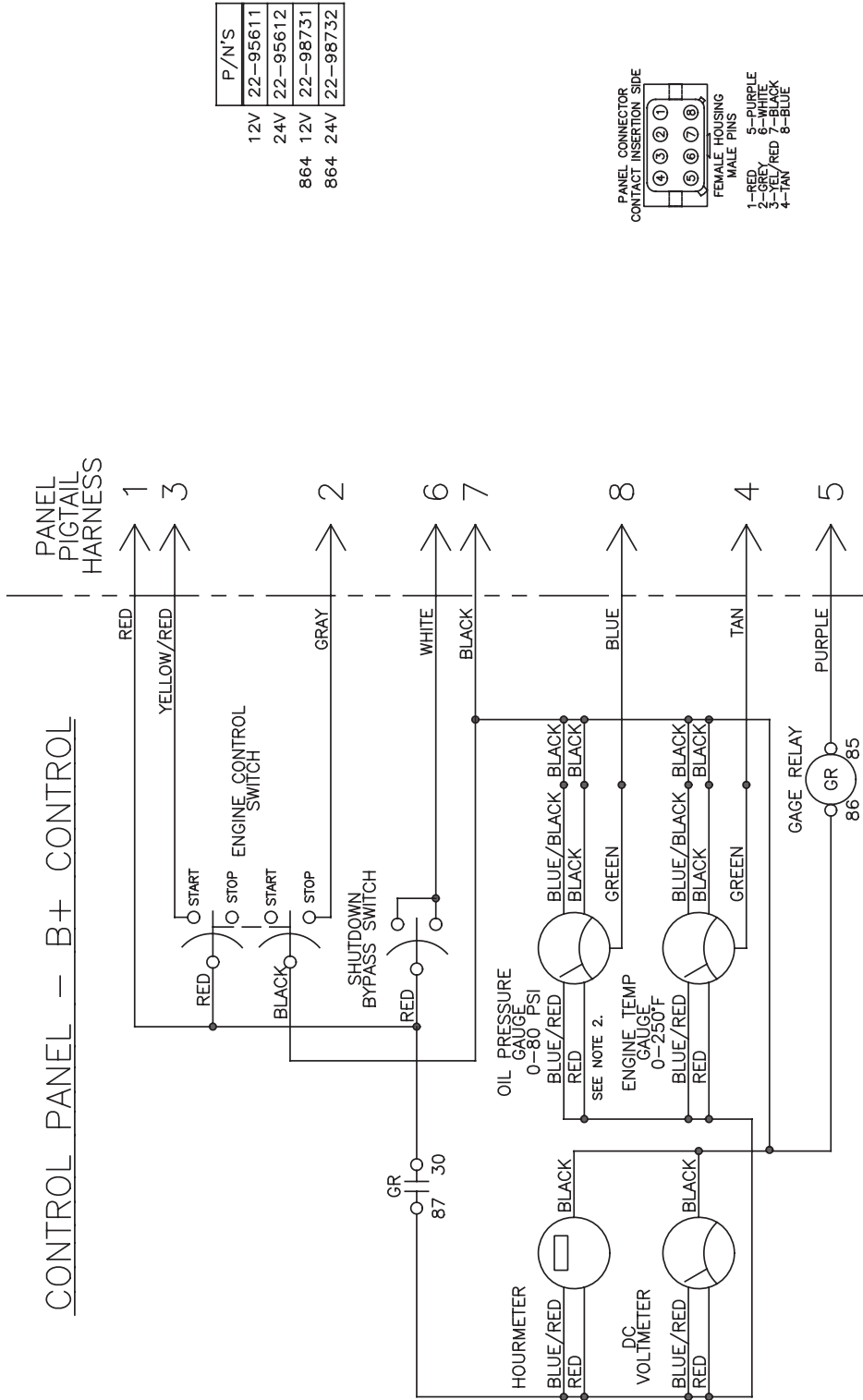

	P/N'S
12V	22-95611
24V	22-95612
864 12V	22-98731
864 24V	22-98732

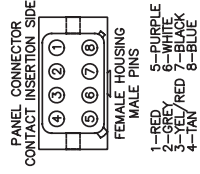

**Panel Wiring Diagram**  
S-1 Panel, B+ Deutsch  
A-12798

- NOTES:**
- ALL INSTALLATION CONDUCTORS ARE TO BE AWG 16, TYPE MTW, 600VAC, 105°C, STRANDED, EXCEPT AS NOTED.
  - OIL PRESSURE GAUGE IS TO BE 0-150 PSI ON PANELS 22-98731 & 22-98732.

## Panel Wiring Diagrams

### CONTROL PANEL - B+ CONTROL

P/N	12/24V
22-95605	MTU
22-95910	DIGITAL HOURMETER
22-95603	

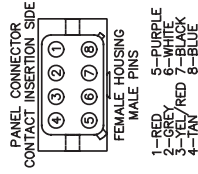
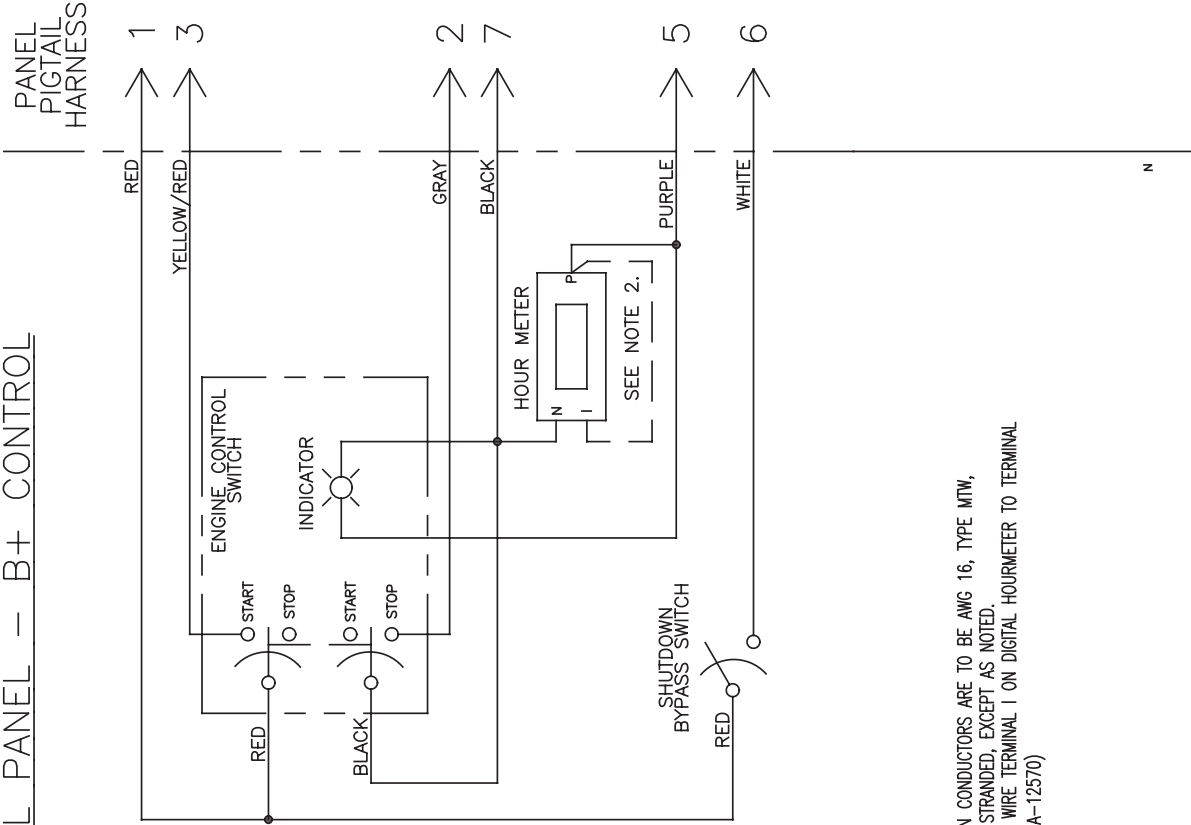

**Panel Wiring Diagram**  
S-1B Panel, B+  
A-12791B

**NOTES:**

- ALL INSTALLATION CONDUCTORS ARE TO BE AWG 16, TYPE MTW, 600VAC, 105°C, STRANDED, EXCEPT AS NOTED.
- FOR 22-95603, WIRE TERMINAL 1 ON DIGITAL HOURMETER TO TERMINAL P. (REFERENCE A-12570)

## Panel Wiring Diagrams

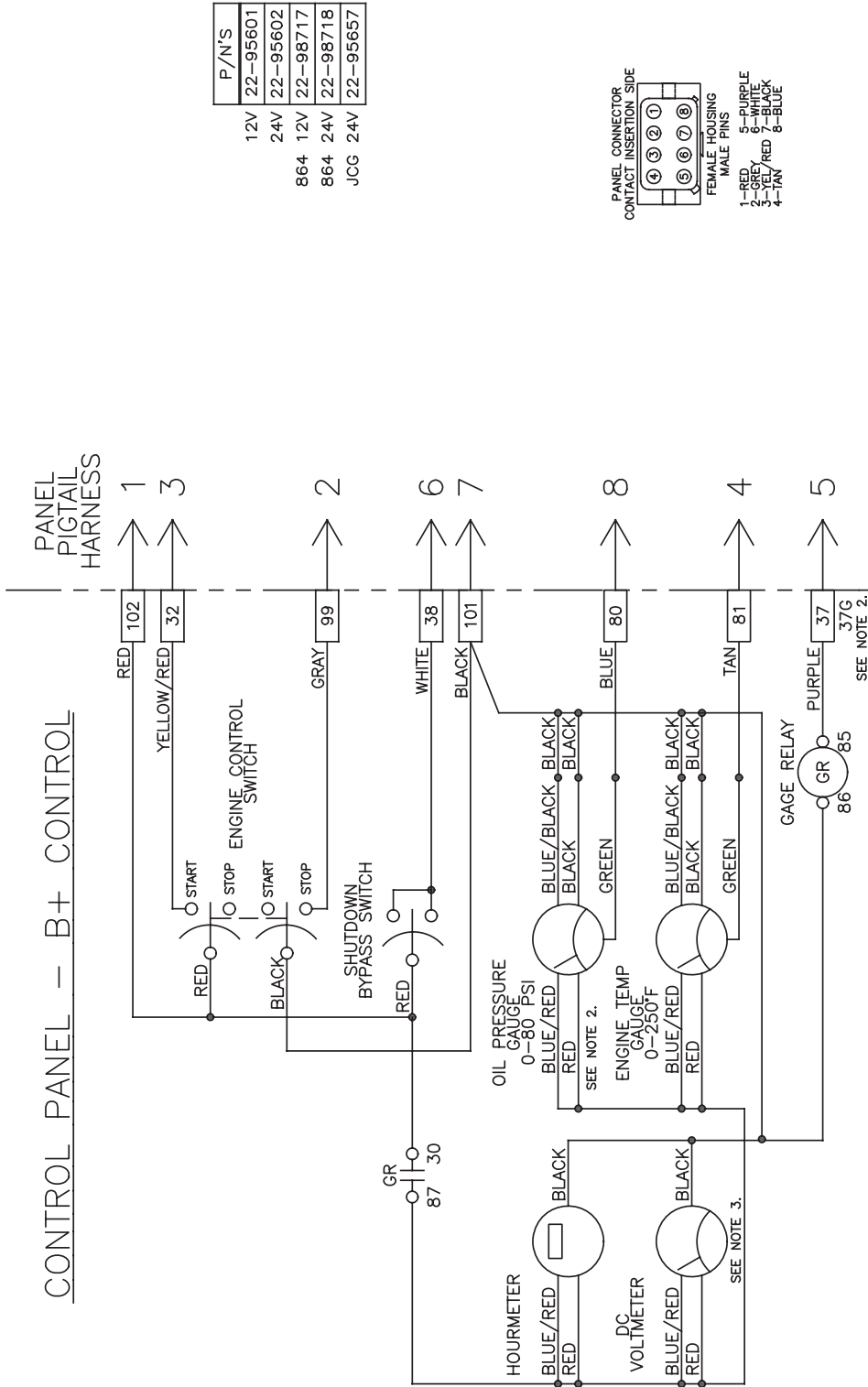

**Panel Wiring Diagram**  
S-3B Panel, Viewline B+  
A-12799A

**NOTES:**

1. OIL PRESSURE GAUGE IS TO BE 0-150 PSI ON PANELS 22-98717 & 22-98718.
2. RELABEL TERMINAL 37 TO 37G WHEN LIGHTING FUSE IS USED. REFER TO DC WIRING DIAGRAM.
3. FOR 22-95657 WITH NO HOURMETER, SECURE EXTRA HARNESS WIRES AND INSTALL A 12 TERMINAL STRIP WITH 4 UNMARKED TERMINALS.

## Panel Wiring Diagrams

### CONTROL PANEL - B+ CONTROL

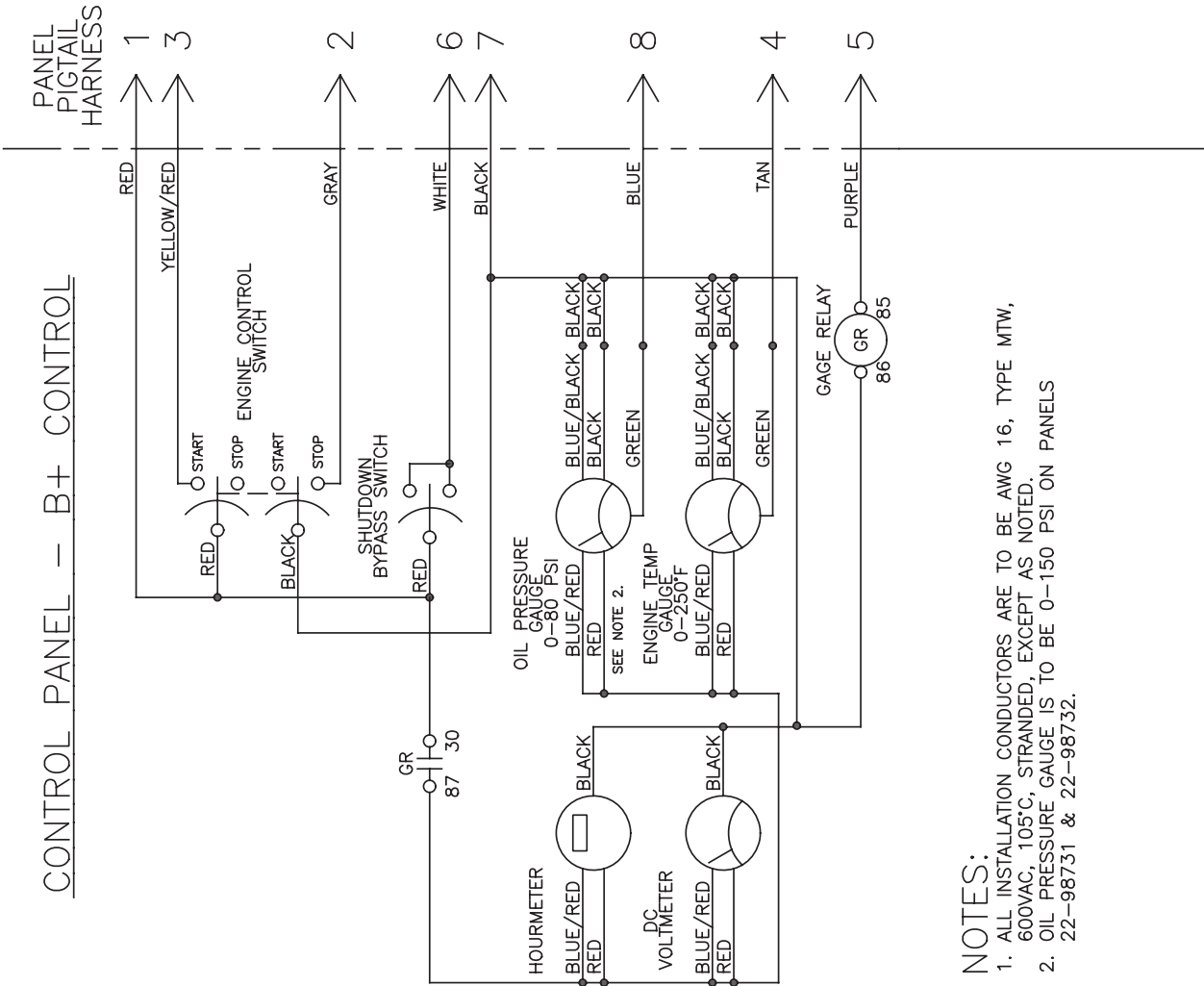

	P/N'S
12V	22-95611
24V	22-95612
864 12V	22-98731
864 24V	22-98732

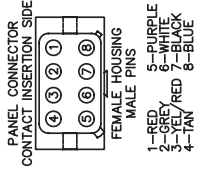

**Panel Wiring Diagram**  
S-3C Panel, Viewline B+  
A-12790A

**NOTES:**

1. ALL INSTALLATION CONDUCTORS ARE TO BE AWG 16, TYPE MTW, 600VAC, 105°C, STRANDED, EXCEPT AS NOTED.
2. OIL PRESSURE GAUGE IS TO BE 0-150 PSI ON PANELS 22-98731 & 22-98732.





## Panel Wiring Diagrams

### CONTROL PANEL

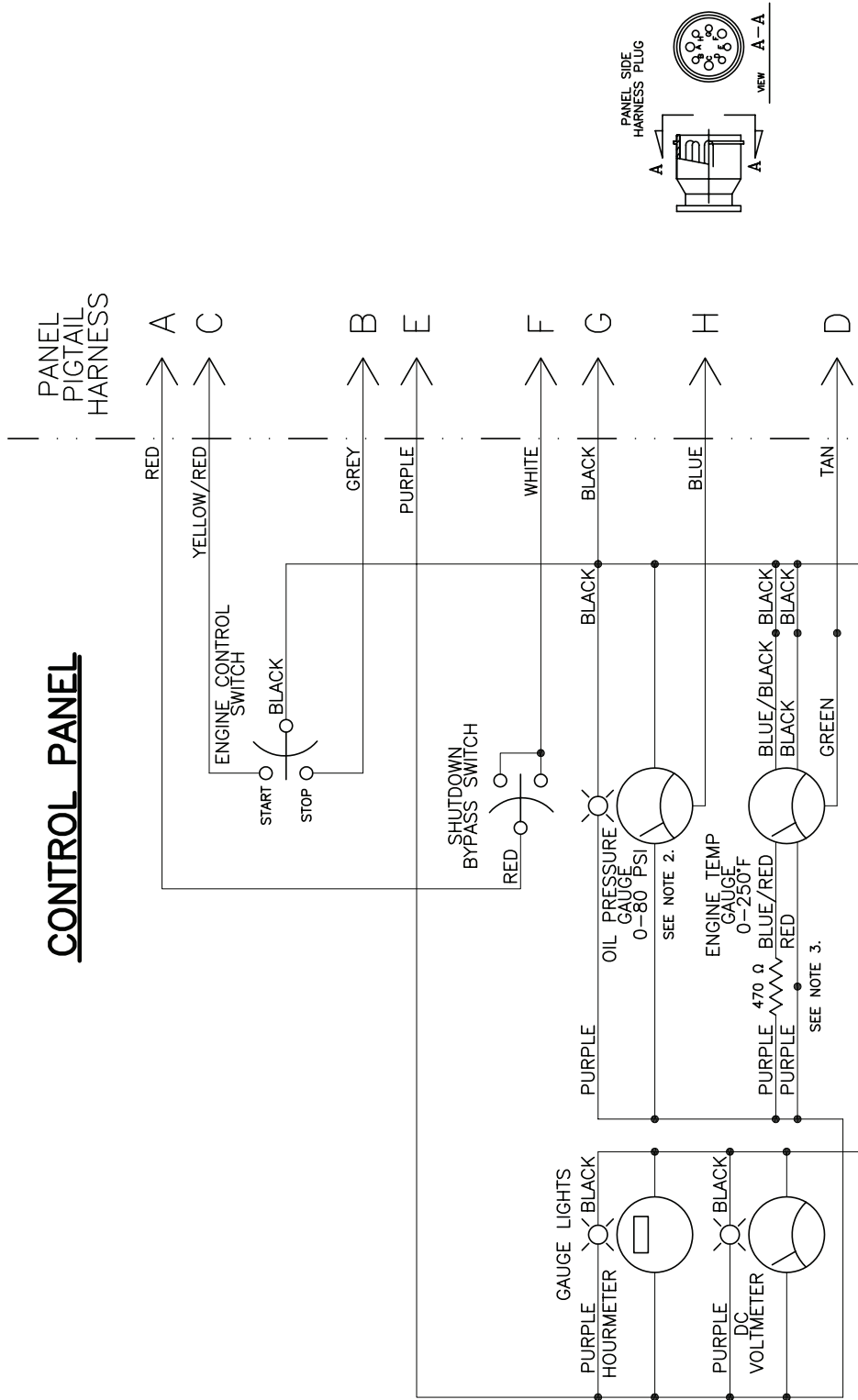

### NOTES:

1. ALL INSTALLATION CONDUCTORS ARE TO BE AWG 14, TYPE MTW, 600VAC, 105°C, STRANDED, EXCEPT AS NOTED.
2. OIL PRESSURE GAUGE IS TO BE 0-150 PSI ON PANEL 22-98706.
3. RESISTOR IS TO BE 470 OHMS, 5% 1/4W OR FROM RESISTOR KIT 22-40611.

**Panel Wiring Diagram**  
S-3C Oceanline / Viewline  
Panels 12V  
Drawing A-12572B

## Panel Wiring Diagrams

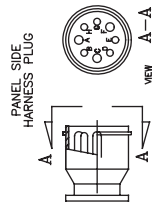
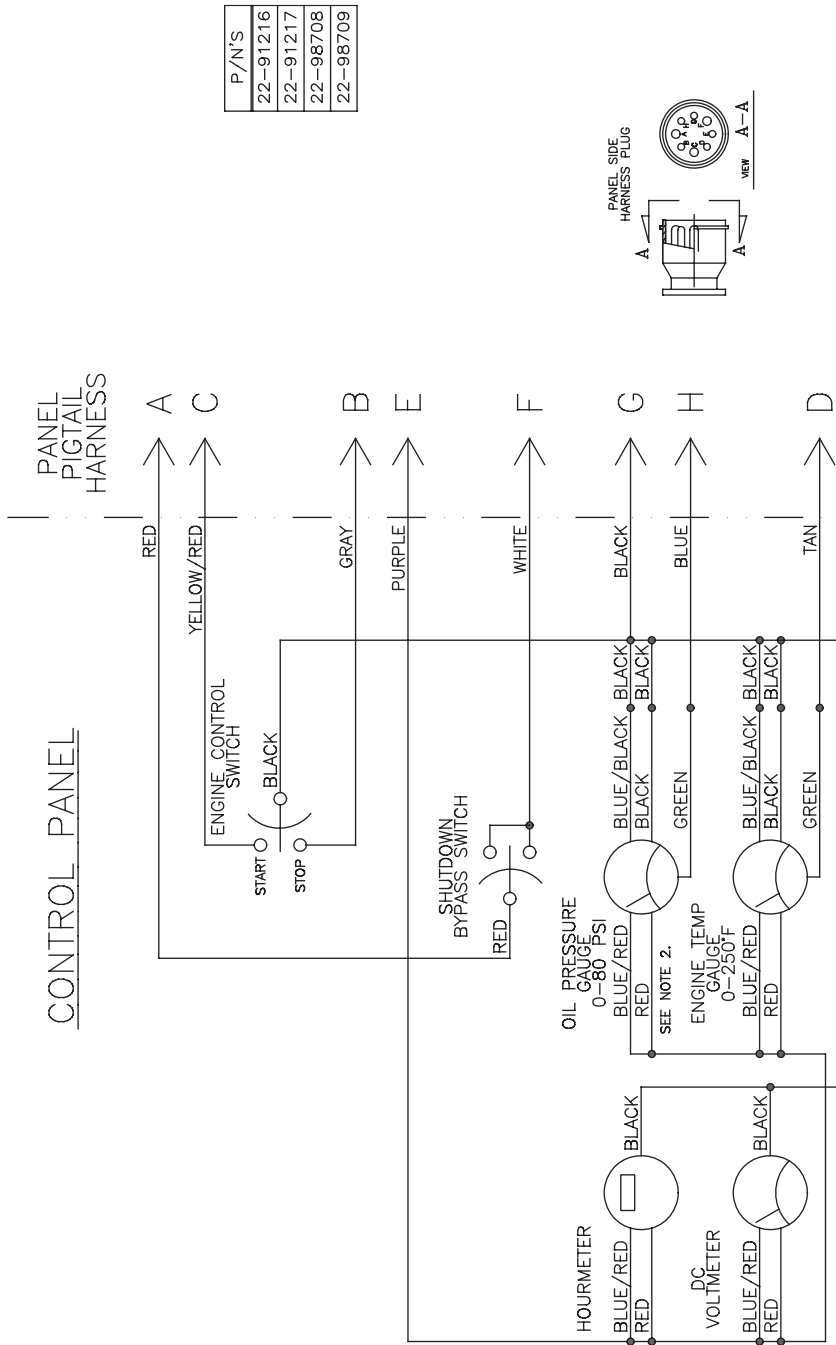

**NOTES:**

1. ALL INSTALLATION CONDUCTORS ARE TO BE AWG 14, TYPE MTW, 600VAC, 105°C, STRANDED, EXCEPT AS NOTED.
2. OIL PRESSURE GAUGE IS TO BE 0-150 PSI ON PANELS 22-98708 & 22-98709.

**Panel Wiring Diagram**  
S-3C Viewline  
Panels 12V  
Drawing A-12645A

# Panel Wiring Diagrams

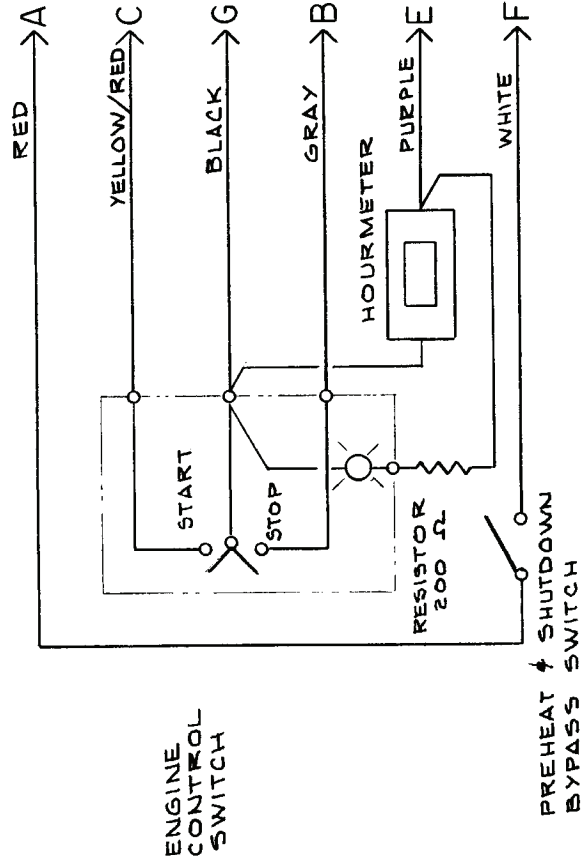
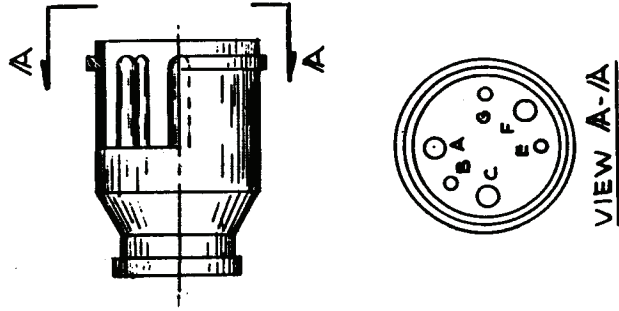

B O M A-4791

**Panel Wiring Diagram**  
for 24 VDC Isolated Ground  
Drawing A-4792

## Panel Wiring Diagrams

### CONTROL PANEL

PANEL  
PIGTAIL  
HARNESS

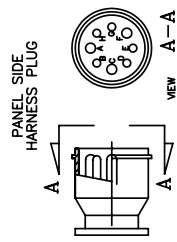
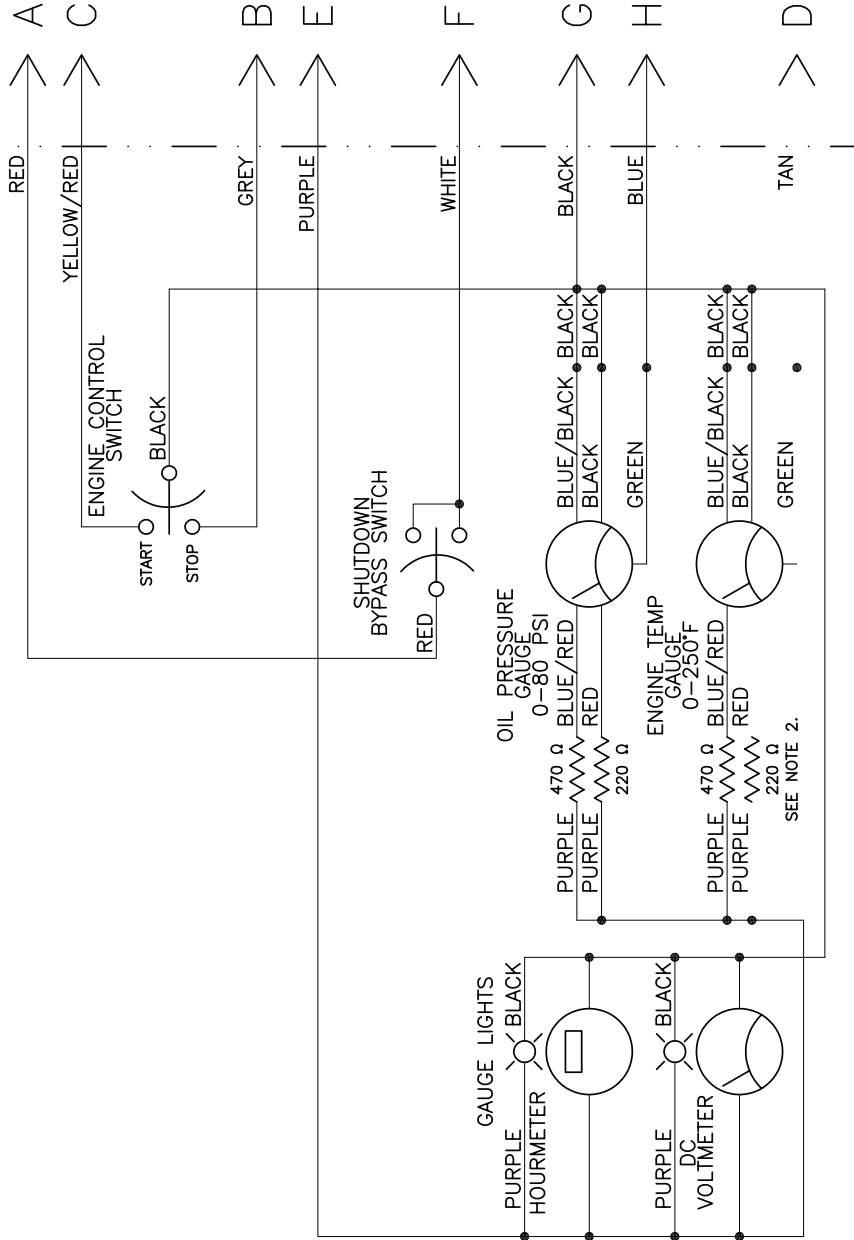

**Panel Wiring Diagram**  
S-3C Oceanline / Viewline  
Panels 24V  
Drawing A-12594B

**NOTES:**

1. ALL INSTALLATION CONDUCTORS ARE TO BE AWG 14, TYPE MTW, 600VAC, 105°C, STRANDED, EXCEPT AS NOTED.
2. RESISTORS ARE TO BE 470 OHMS 5% 1/4W AND 220 OHMS 5% 2W.









4420 14th Ave. NW., Seattle WA 98107

Tel: (206) 789-3880 • 1-800-762-0165 • [www.northern-lights.com](http://www.northern-lights.com)

Northern Lights and Lugger are registered trademarks of Northern Lights, Inc.

© 2019 All rights reserved. Litho USA.